



PROYECTO FIN DE CARRERA



revitalización de una manzana del casco viejo de Vitoria

revitalization of a city block in the old quarter of Vitoria

AMAIA LOS ARCOS LARUMBE

El objeto del presente proyecto es revitalizar el Casco Antiguo de Vitoria mediante la intervención en una manzana completa. El comercio ha fracasado dentro del Casco Antiguo; a esto hay que añadirle el éxodo de la población hacia otras zonas de la ciudad, además del envejecimiento de la gente que todavía reside en esta zona de la ciudad. El Centro Histórico se convierte de este modo en un espacio protegido, pero abandonado. Con la intención de revitalizar este entorno se plantea un programa que aglutine distintos usos. Se opta por un Centro de Expresión Artística, un espacio de reunión donde se pueda conciliar la cultura para poder ampliar su forma de expresión. Un lugar donde los creadores puedan desarrollar libremente su labor creativa. La base del proyecto es una carencia: la necesidad de espacios expositivos, de creación, de encuentro entre artistas y público, de proyección que se adapten al concepto contemporáneo del arte. Se fusionarán espacios expositivos, espacios de cesión a los artistas para la realización de sus proyectos y zonas polivalentes, tanto interiores como exteriores, con la intención de crear un espacio público bastante escaso en el Centro Histórico. Con la intención de garantizar la vida diaria de la zona se complementará este uso público en plantas superiores con pequeños comercios y apartamentos en alquiler, ya que nos encontramos en una de las mejores zonas de la ciudad para vivir.

The aim of the present project is to give new life to the Old Quarter of Vitoria by doing works on an entire city block. Shops have failed in the Old Quarter, to which we must add the general exodus of the population to other areas of the city and the ageing of those who do still reside in this area. The Historical Centre has thus become a protected, yet abandoned space. With the intention of revitalizing the neighbourhood, we suggest a design which would combine various uses. Included would be a Centre for Artistic Expression, a meeting place whose aim is to obtain a cultural balance in favour of broadening cultural expression. A place where creators can freely carry out their projects. The foundation of the project is a need: the need for exhibit spaces, areas for artistic creation, projection facilities and a place for artists and the public to come together; all of which adapt to the contemporary concept of art. Exhibit spaces would merge with areas provided for artists to create their projects and multipurpose areas, both indoors and out, with the aim of creating a public space of which there are very few in the Historical Centre. And in order to guarantee viable daily living in the area, public use of this space would be complemented on upper floors with small business and apartments for rent, as we are in one of the finest areas of the city to live.



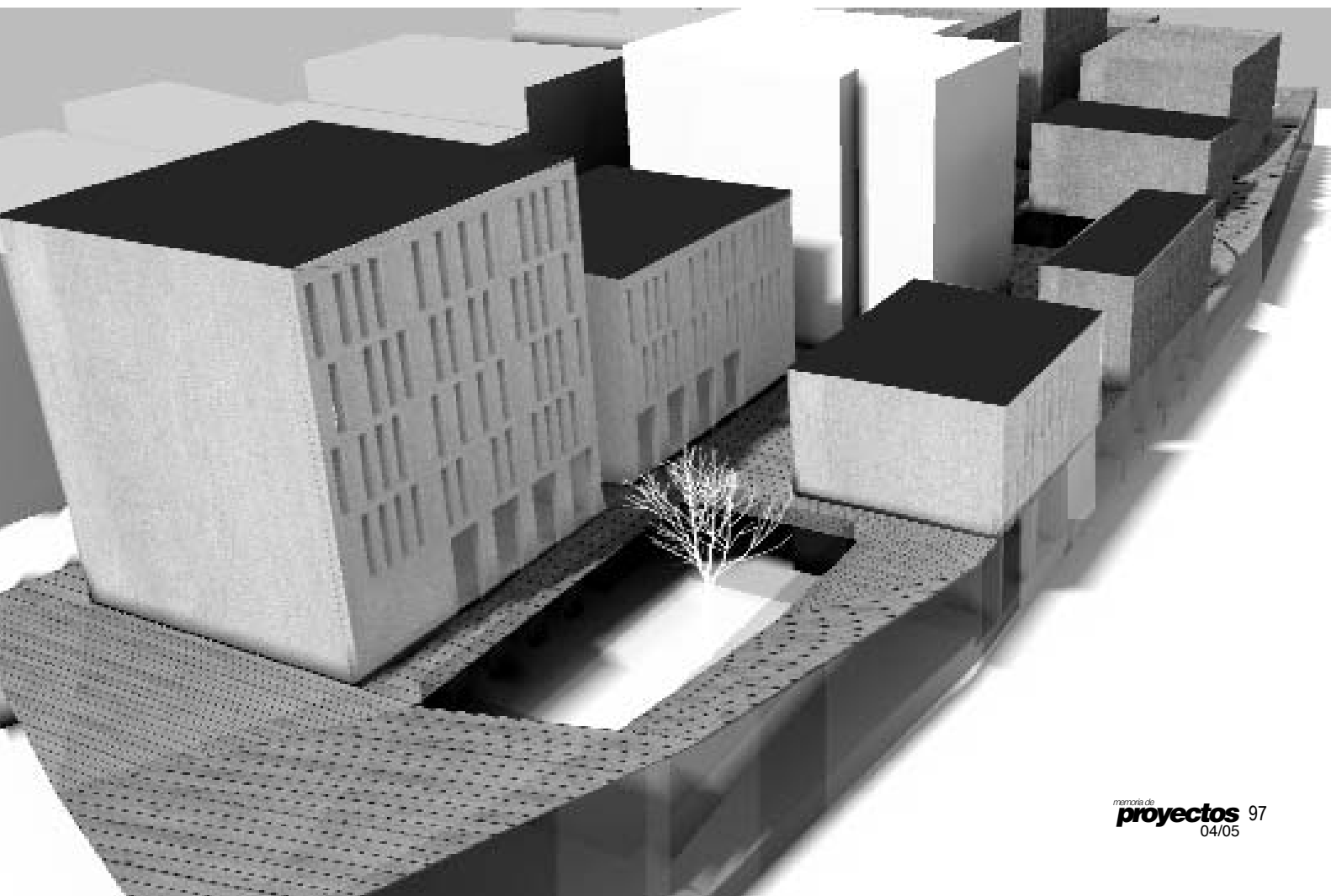
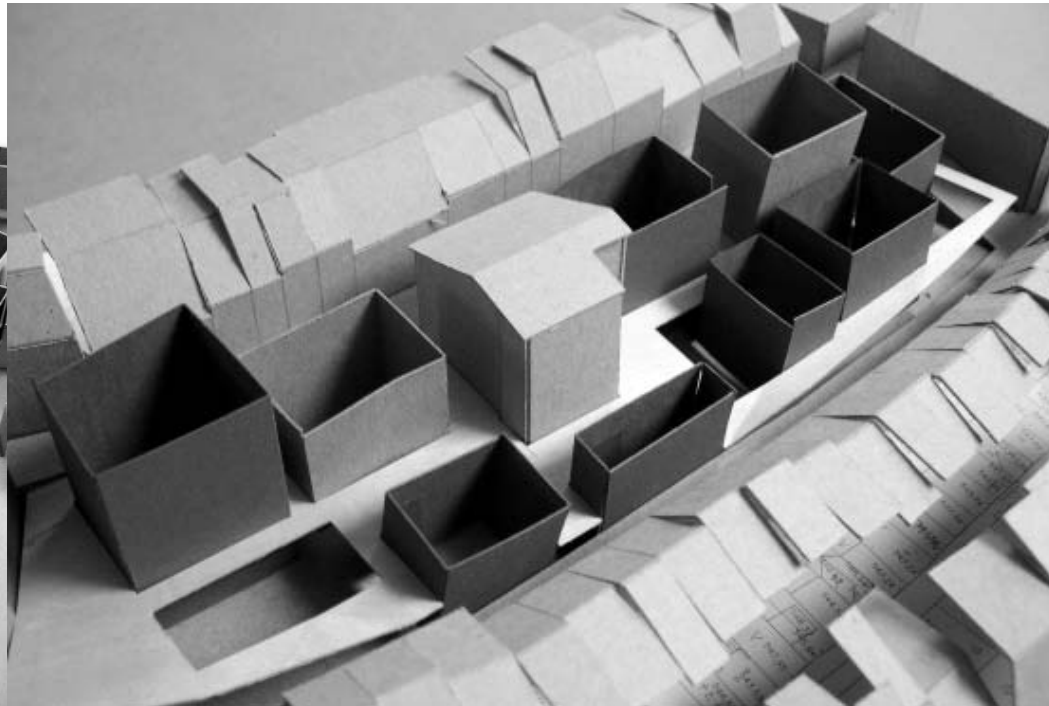
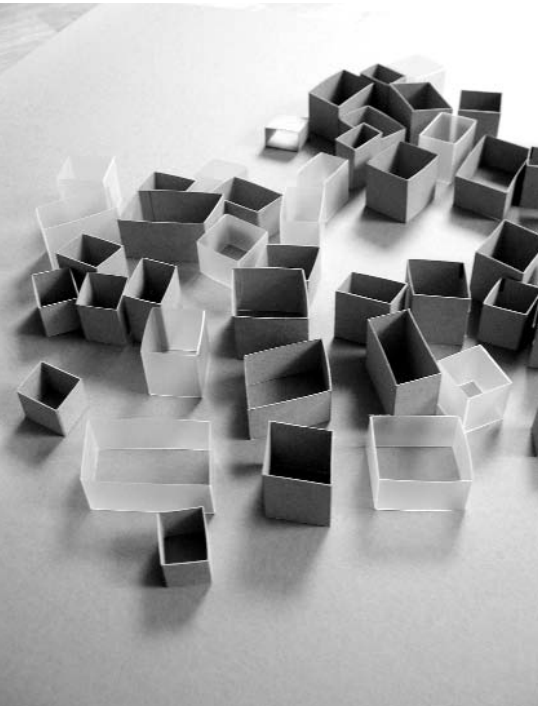

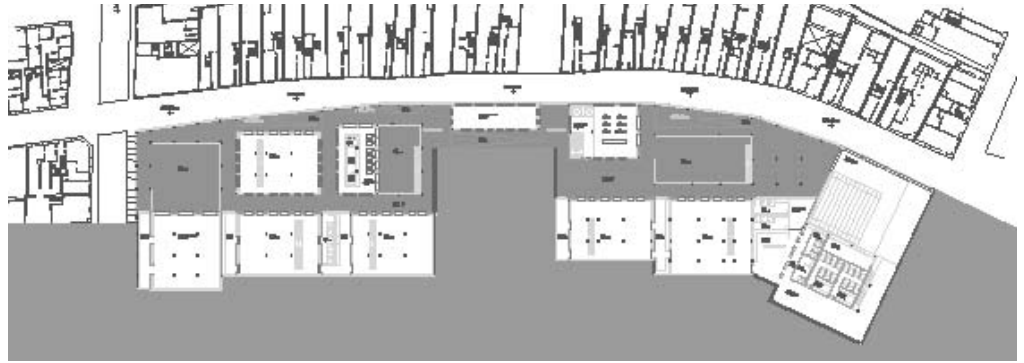

nivel 0
level 0

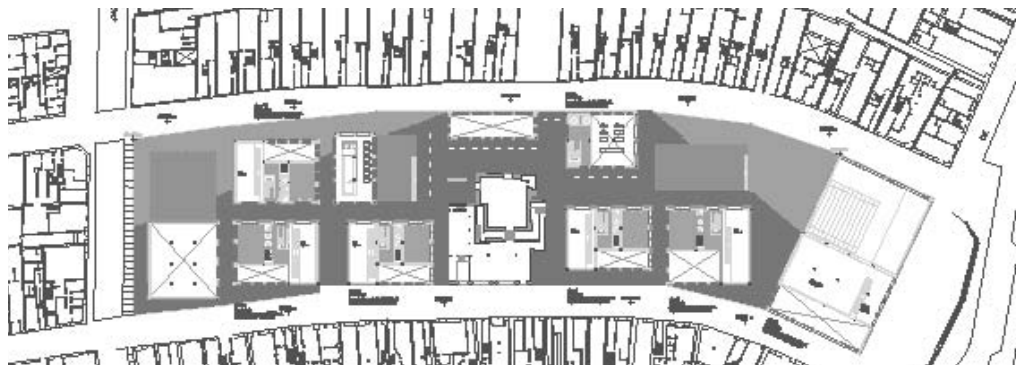

nivel +1
level +1

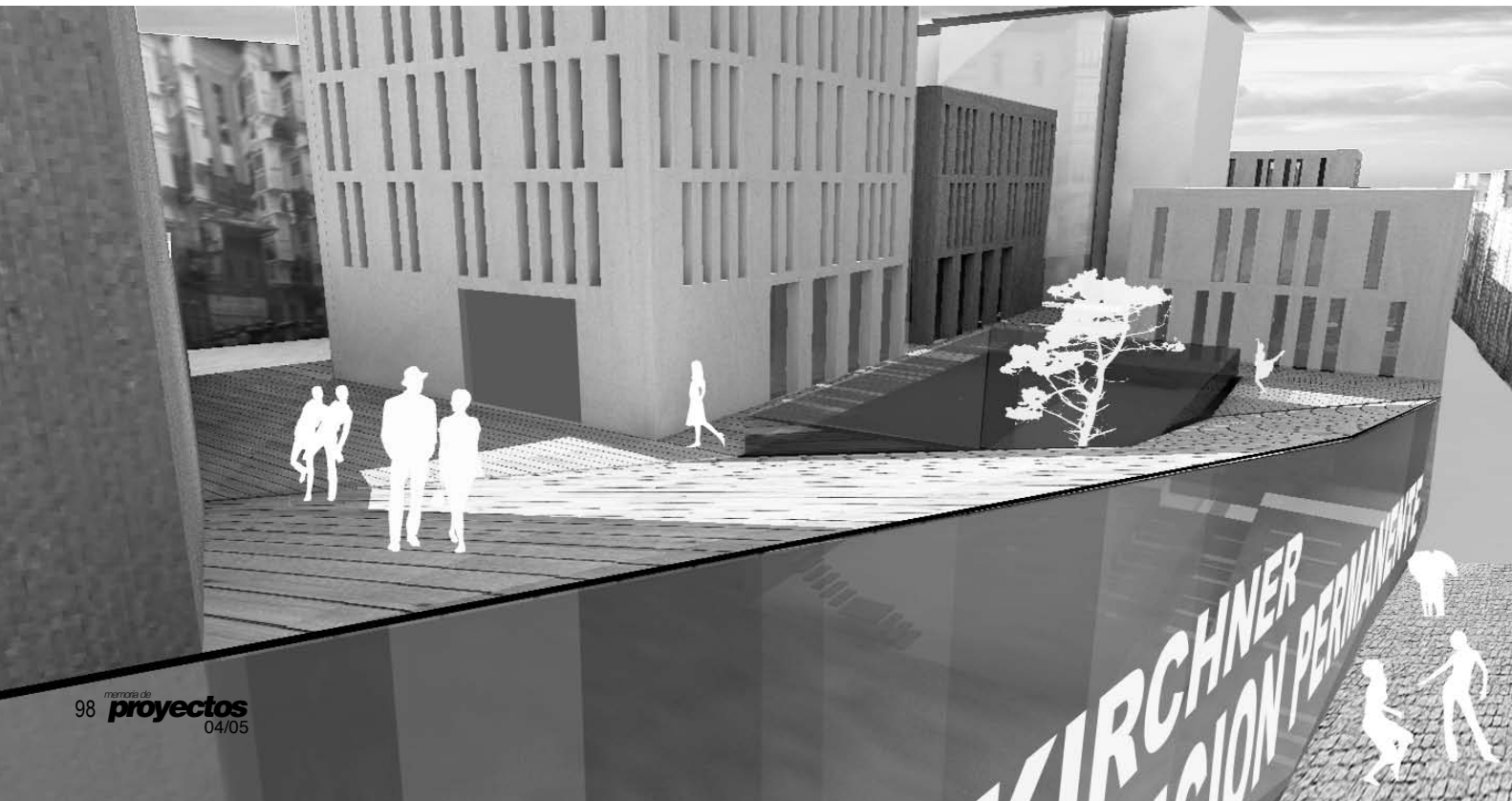



nivel +2
level +2

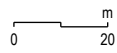
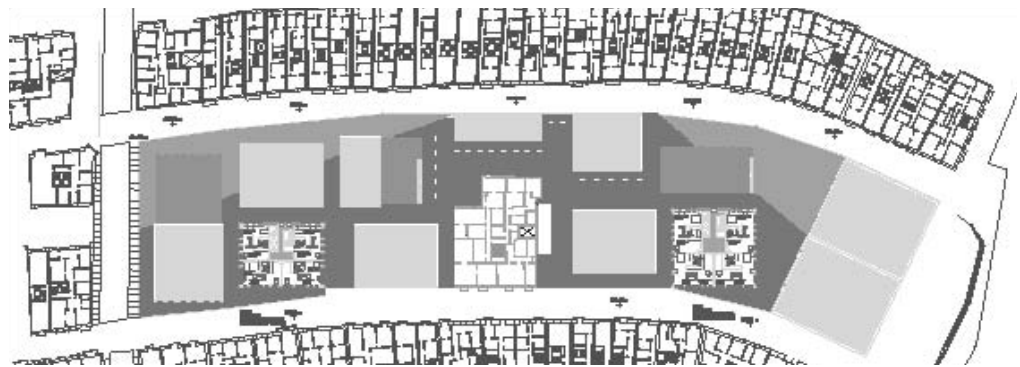

nivel +3
level +3



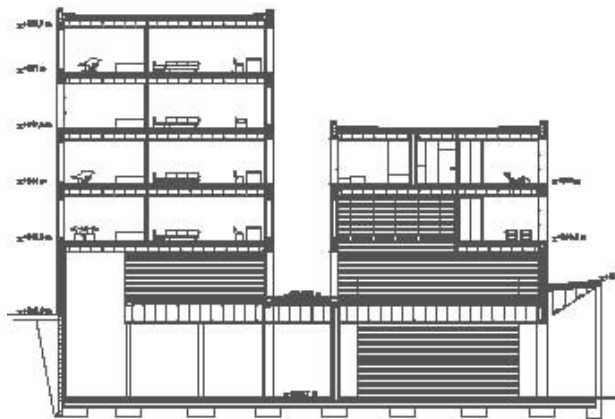

sección transversal A
cross section A

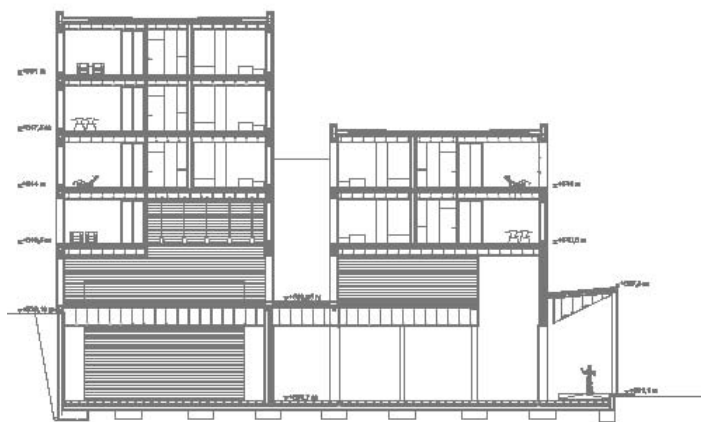

sección transversal B
cross section B

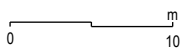

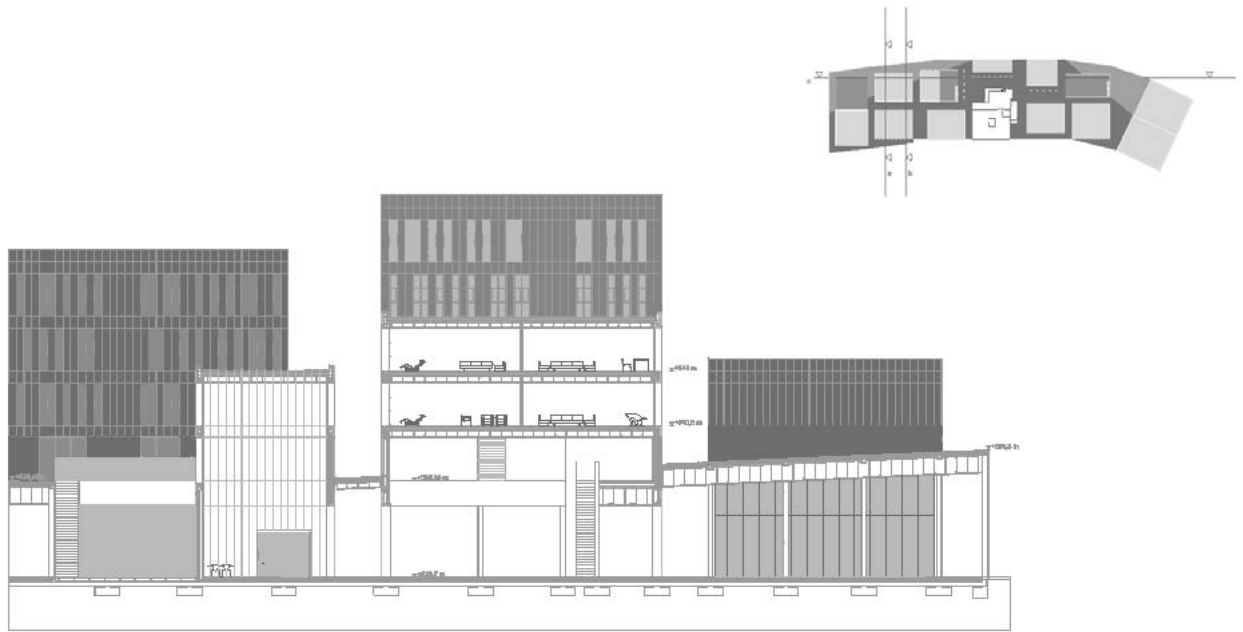

sección longitudinal C
long section C



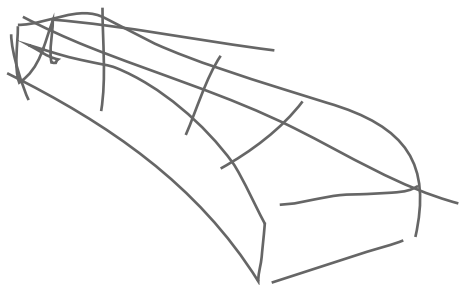

revitalización de una manzana del casco viejo de vitoria

revitalization of a city block in the old quarter of vitoria

BEATRIZ MARTÍNEZ

JAVIER GIL AYESA

Nos encontramos ante un espacio urbano cuya condición medular para la memoria y la cultura resulta clave para los que lo habitan y lo visitan. Clave para conseguir la regeneración de éste y para enriquecerse de actividades culturales y comerciales de manera conjunta con el resto de la ciudad. Se trata de la construcción de un Centro para artistas que se convierta en el catalizador del arte de la ciudad de Vitoria-Gasteiz, para los visitantes y por supuesto para sus habitantes. Se pretende con este centro completar el itinerario cultural entre el Artium y Monte Hermoso, dotando a la ciudad de un punto de encuentro de artistas, donde estos puedan hallar un lugar de trabajo, investigación, experimentación y de diálogo entre ellos y la ciudad dotándola de un nuevo espacio dedicado al trabajo, exposición de arte, pudiendo completar así las carencias actuales de la ciudad. El edificio se concibe como un reclamo de los habitantes de la ciudad creando y ofertado espacios para la observación, el estudio, el ocio y la investigación, dentro del casco antiguo de la ciudad. Asimismo se logra una revitalización del casco antiguo mediante la introducción de una nueva actividad cultural de la que la propia ciudad es partícipe.

We find ourselves before an urban space whose fundamental role in memory and culture is key for those who live here or for those who just visit. Key to the regeneration of the area and to enriching the local cultural and commercial activities in order to keep up with the rest of the city. The project includes the construction of a Centre for artists which would act as a catalyst for art in the city of Vitoria-Gasteiz, both for visitors and for residents. The aim of this centre is to complete the cultural itinerary which exists between the Artium and Monte Hermoso, providing the city with a meeting point for artists where they will find a place to work, experiment, carry out their research and exchange ideas among themselves and with the city. This new space devoted to work and art exhibitions would thus cover one of the city's current shortcomings. The building has been conceived of as a call to the city's inhabitants, creating and offering spaces for observation, study, entertainment and research, all within the city's old quarter. The result would be a revitalization of the city centre through the introduction of new cultural activity in which the city itself is able to participate.

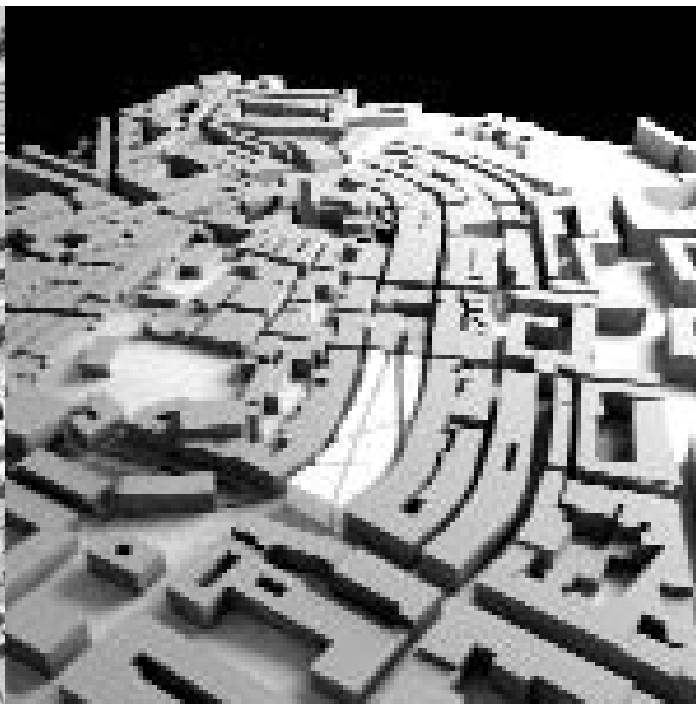

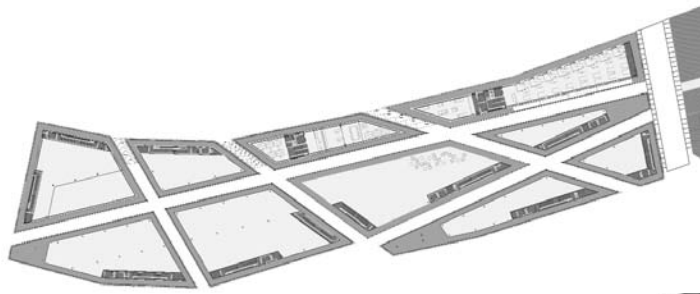

planta segunda
second floor

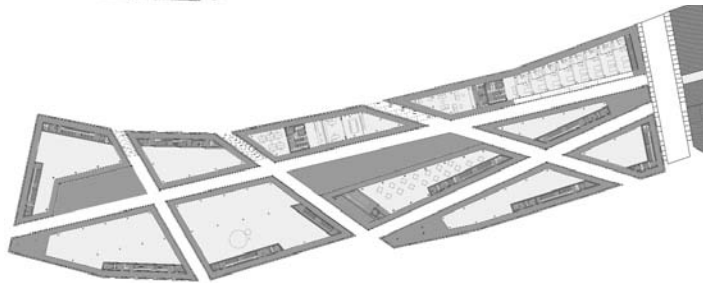

planta primera
first floor

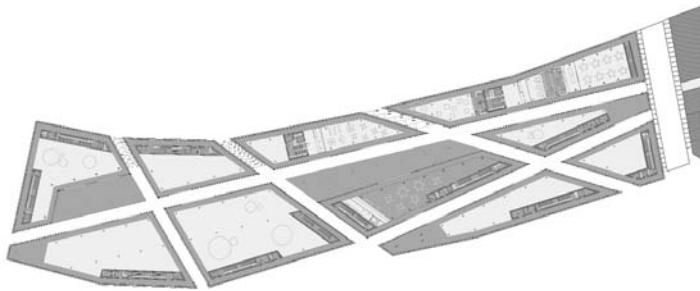

planta baja
ground floor

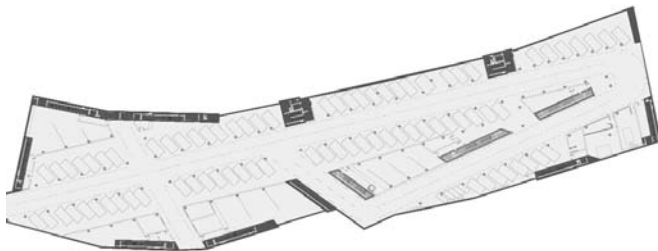

planta sótano
basement floor

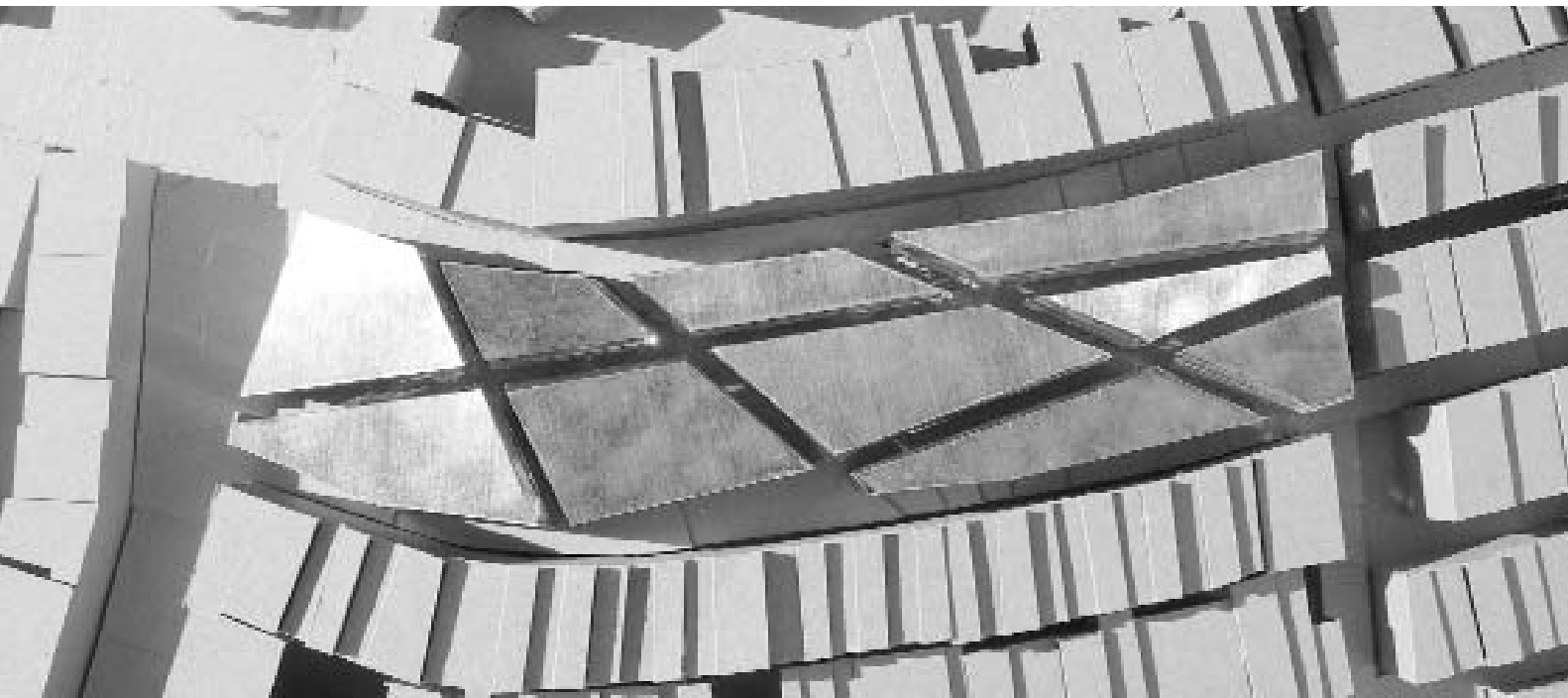
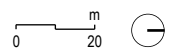

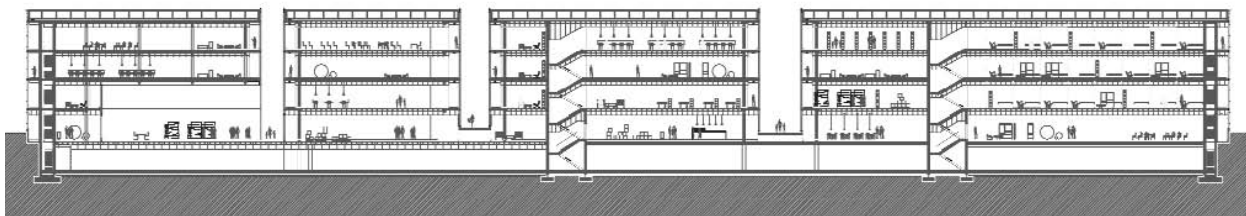
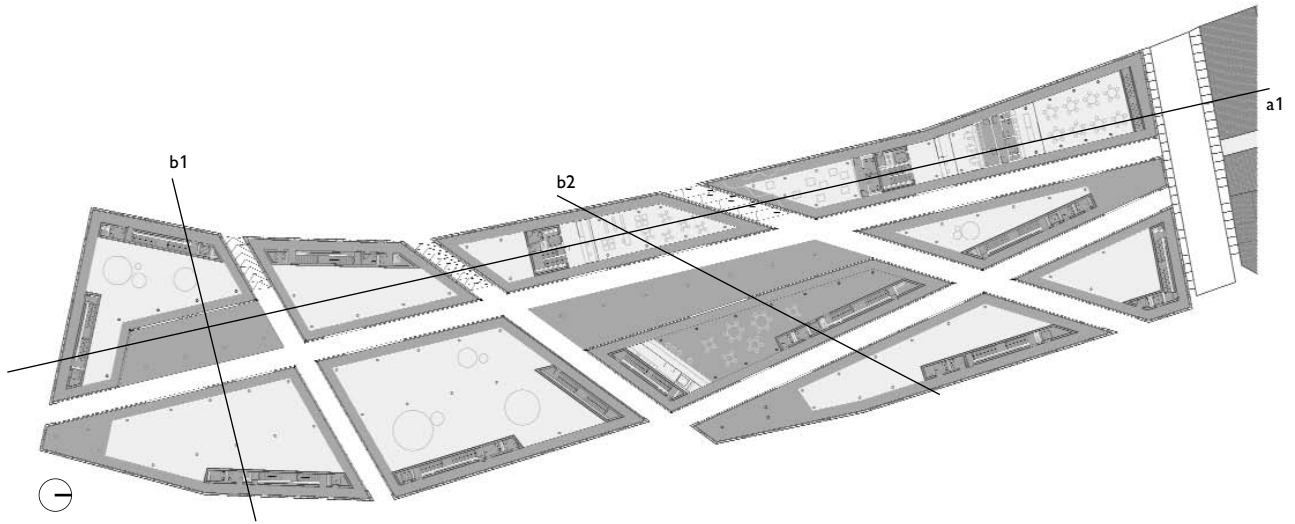

sección longitudinal a1
long section a1

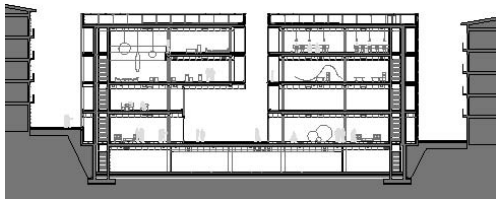

sección transversal b1
transversal section b1

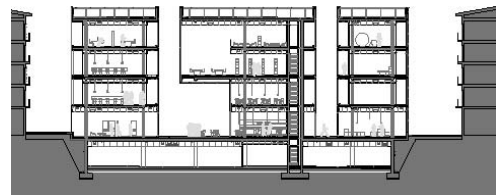

sección transversal b2
transversal section b2

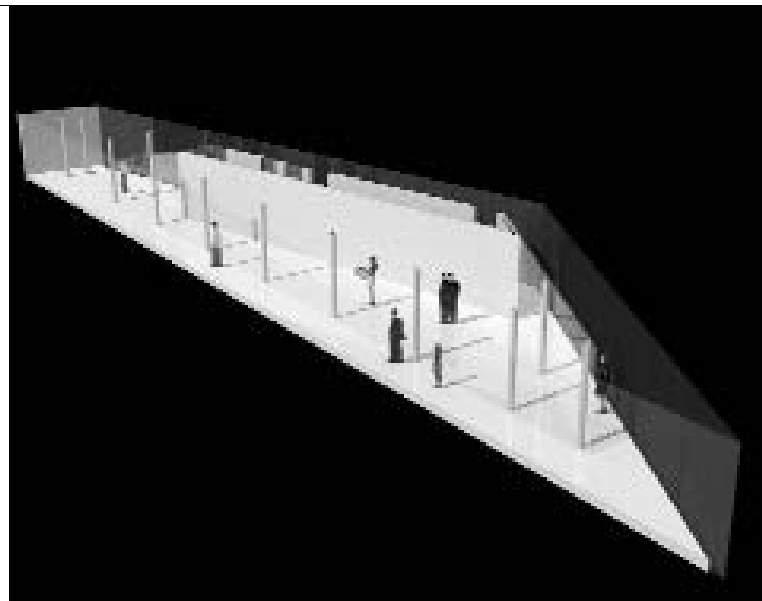
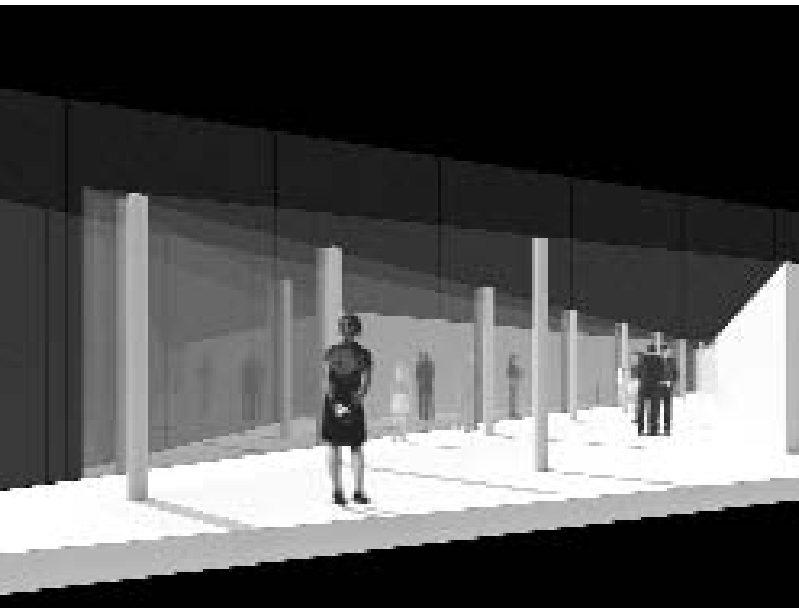
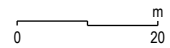

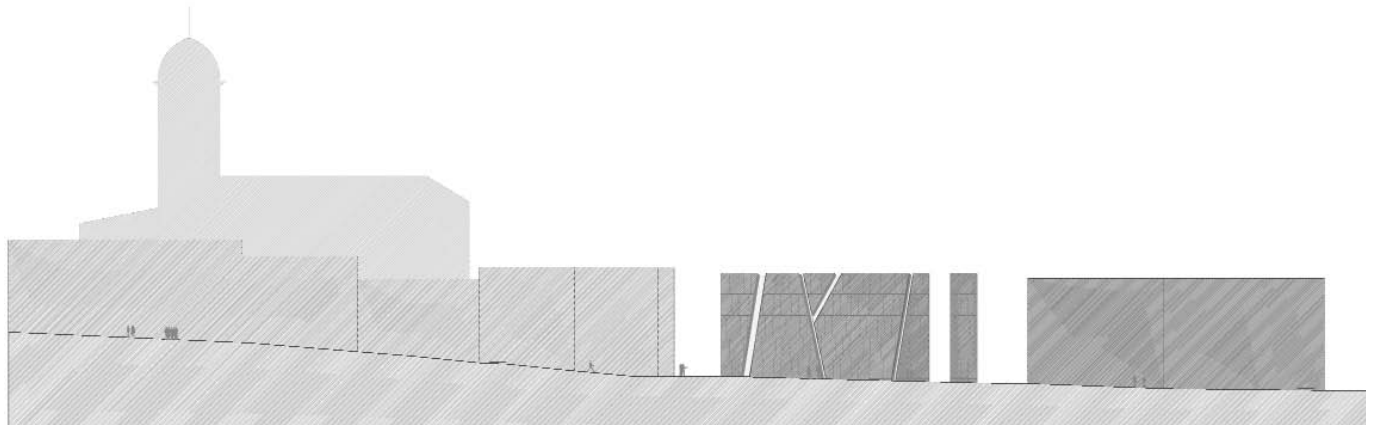

alzado lateral
side elevation

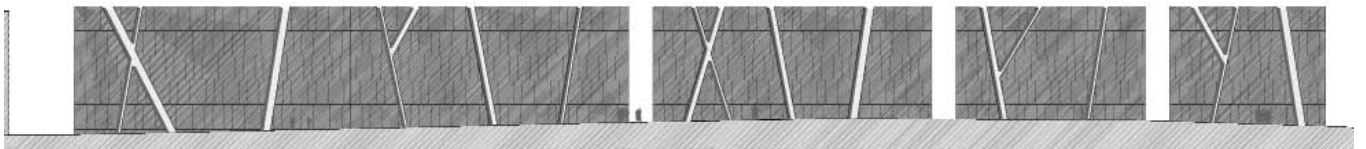

alzado frontal
front elevation



alzado posterior
back elevation

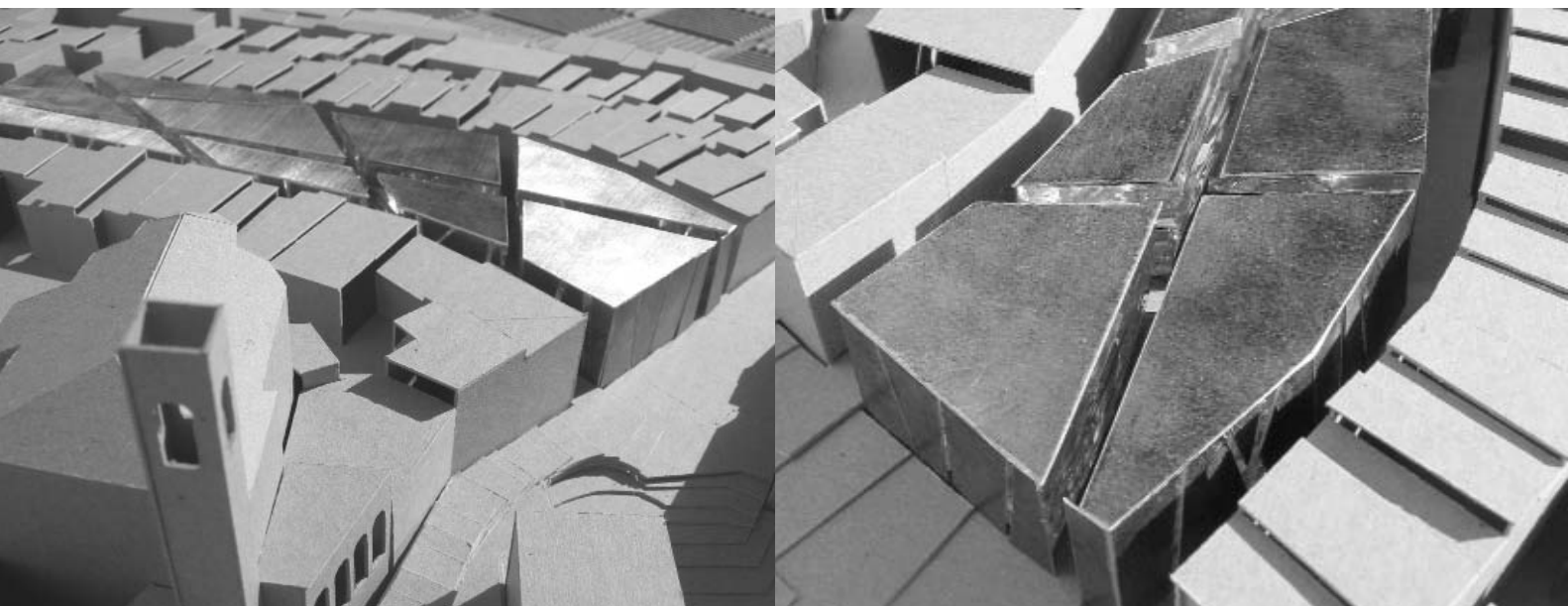
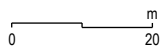

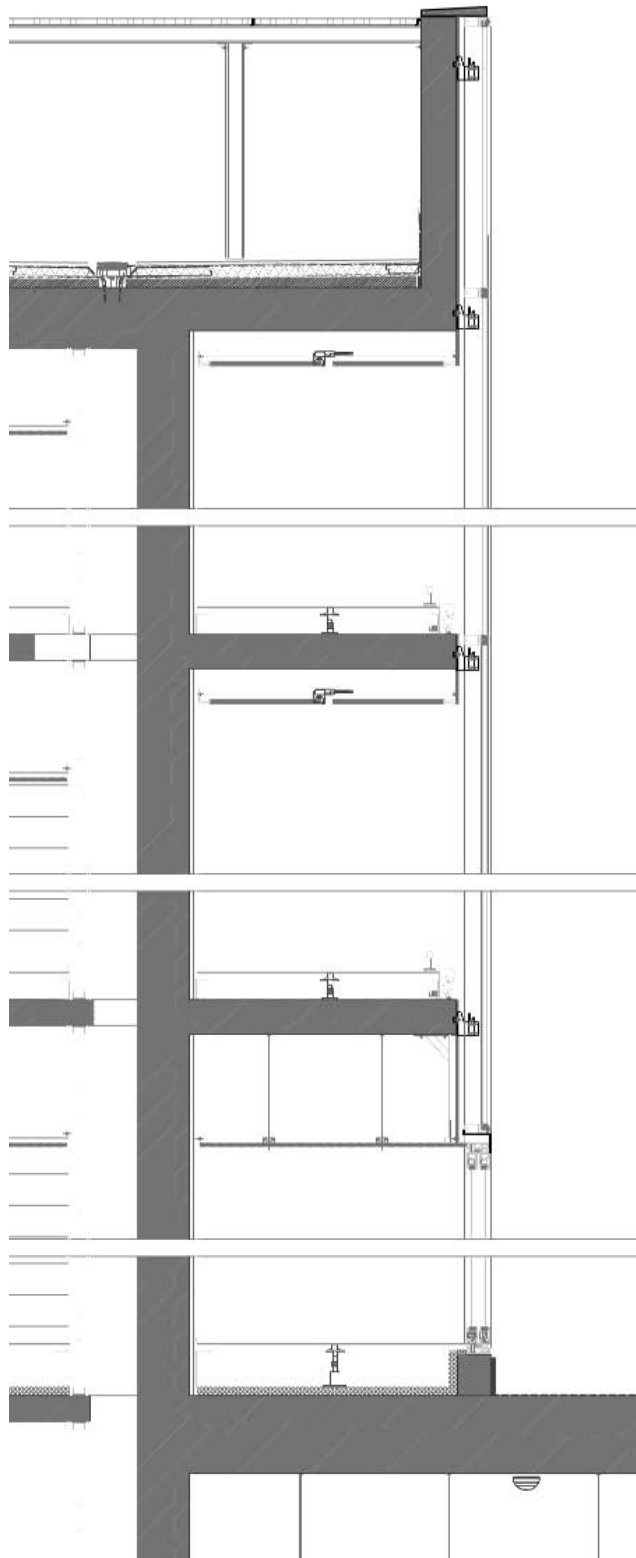
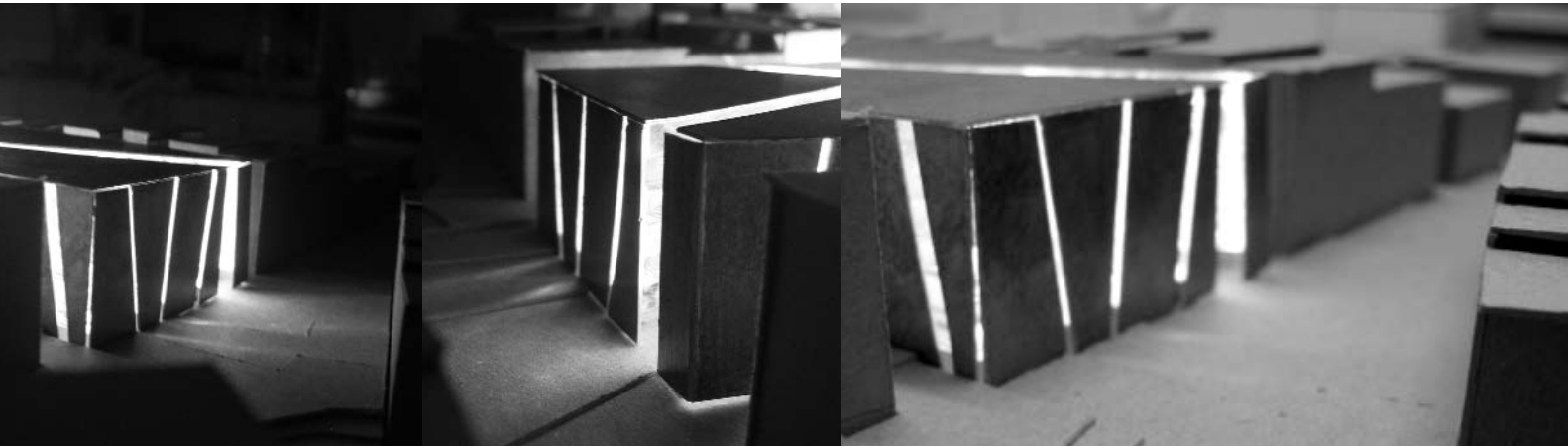

detalle constructivo
constructive detail

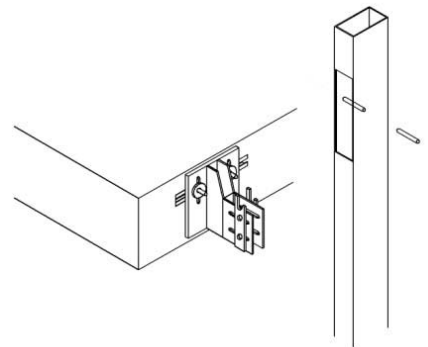

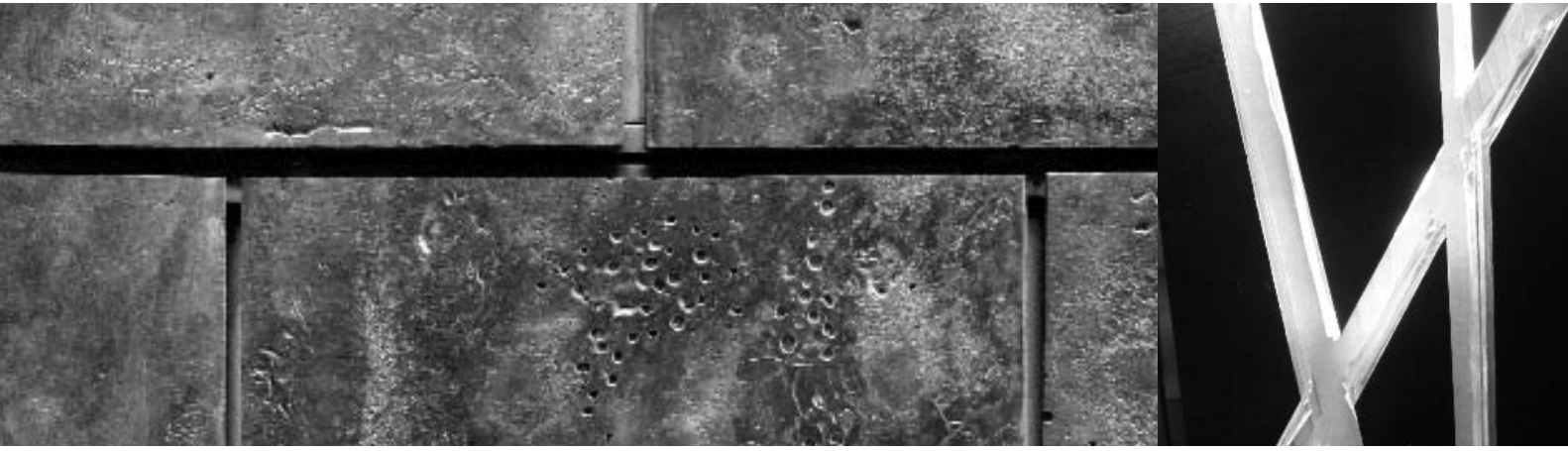

secciones constructivas
constructive sections

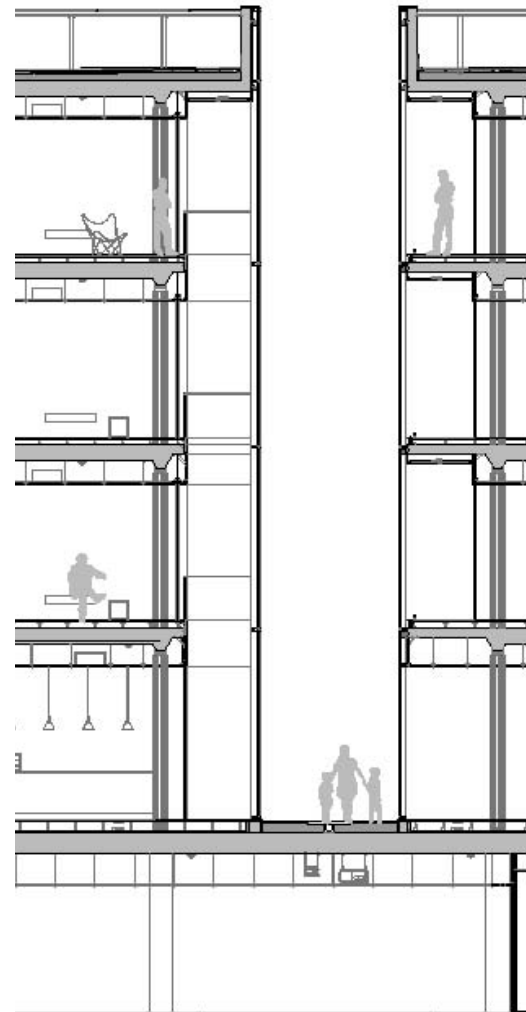
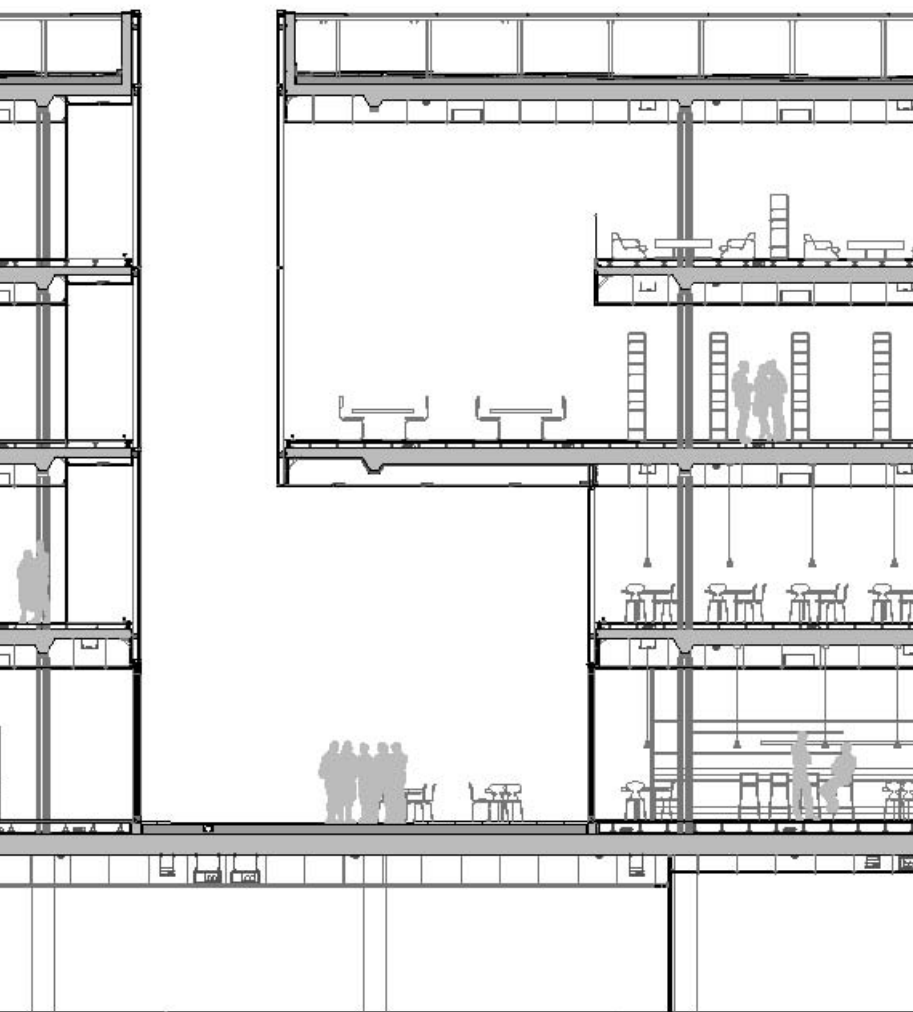

0 5 m



escuela de diseño textil y moda en la ría de Bilbao

school of textile and fashion design on the ría de Bilbao

IÑIGO ARAIZ

Se propone una intervención integral sobre las edificaciones que en su día pertenecieron a la industria Artiach, en concreto sobre un edificio de oficinas (Edificio Artiach) y una nave destinada a producción (Edificio Duquesa María). El conjunto sobre el que se interviene forma parte del conjunto de edificaciones que se mantienen en pie en el master plan de Zaha Hadid para la península de Zorrozaurre, en Bilbao. Alberga una comunidad pequeña pero “vibrante” de unos 500 vecinos y un gran número de fábricas, la mayoría abandonadas. Es en este entorno, de marcado carácter industrial, y aprovechando en parte las edificaciones existentes anteriormente mencionadas, donde se decide ubicar el edificio objeto de proyecto, así como una serie de espacios residenciales de distinto carácter (residencia de estudiantes, lofts para profesores y un hotel ETAP). Se entiende que existen dos paquetes distintos de programa, uno de carácter residencial, y otro en relación con el mundo de la moda. Se destina cada paquete de necesidades a uno de los dos edificios sobre los que se interviene, resultando el Edificio Artiach el que acoge todo el paquete residencial y el Duquesa María el que queda vinculado a las actividades relacionadas con la moda. Una vez definido el carácter de cada edificio, se diferencian tres líneas de programa, cada una con un tipo de “usuario” distinto (visitantes, alumnos y profesores). Dichas líneas distribuyen su parte asignada de programa entre los dos edificios, según las actividades vinculadas a ellas sean de carácter residencial o docente. Para ello se establecen los vínculos necesarios entre los extremos residencial y educacional. De esta forma, mientras que el edificio Artiach muestra a la ciudad la forma de habitar en el mundo de la moda y el Duquesa María ejerce de muro publicitario hacia Bilbao, hacia el interior se da un desfile infinito de personas, estilos, actitudes, tendencias... que retroalimentan el espíritu de creación propio de la escuela.

Here we propose an all-embracing project which would take in all of the buildings which at one time belonged to the Artiach industry, in particular an office building (the Artiach Building) and the premises devoted to production (the Duquesa Maria Building). The complex upon which we propose to work forms part of a group of buildings which remain standing as part of the master plan of Zaha Hadid for the Zorrozaurre Peninsula in Bilbao. It houses a small, yet vibrant community of some 500 residents and a large number of factories, the majority of which are abandoned. It is in this markedly industrial area, taking advantage in part of the previously existing buildings, where we have decided to locate our project building, as well as a series of residential spaces of various types (student residence hall, lofts for teachers and an ETAP hotel). There are two different parts to the programme: one which is clearly residential, and the other which relates to the world of fashion. Each needs package is programmed for one of the two buildings on which we plan to work, with the Artiach Building covering residential needs and the Duquesa Maria responding to activities related to fashion. Now that the character of each building has been defined, we can point out three separate lines within the program, each with a different type of “user”: visitors, students and professors. These lines distribute their assigned track of the programme between the two buildings, depending on whether the activities to take place are residential or teaching-related, establishing in this way the required connections between the residential and the educational extremes. And so, while the Artiach Building shows the city the manner of living within the world of fashion and the Duquesa Maria acts as a wall of advertising for the city of Bilbao, inside we find an endless procession of people, styles, attitudes and tendencies which act as feedback for the spirit of creation of the school.



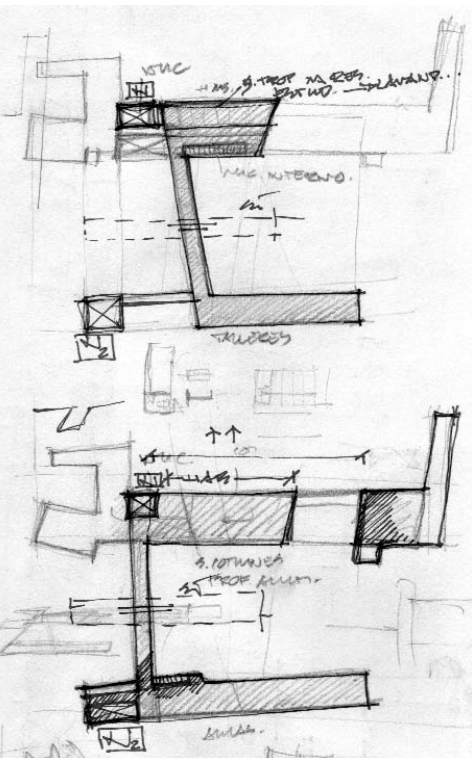

planta baja
ground floor

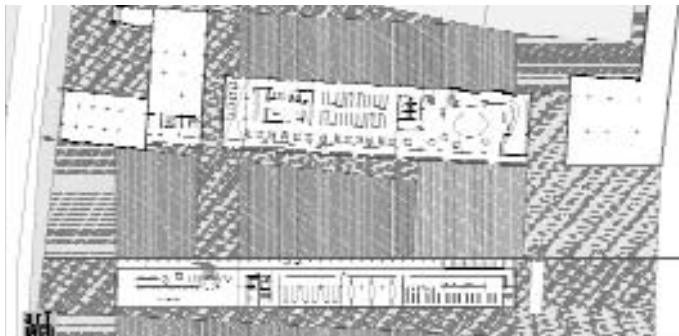

planta primera
first floor



planta segunda
second floor

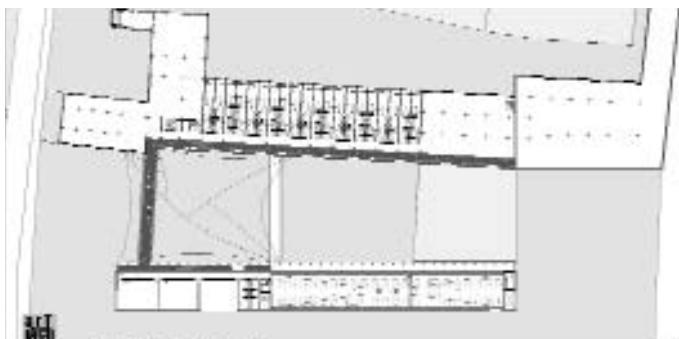

planta tercera
third floor

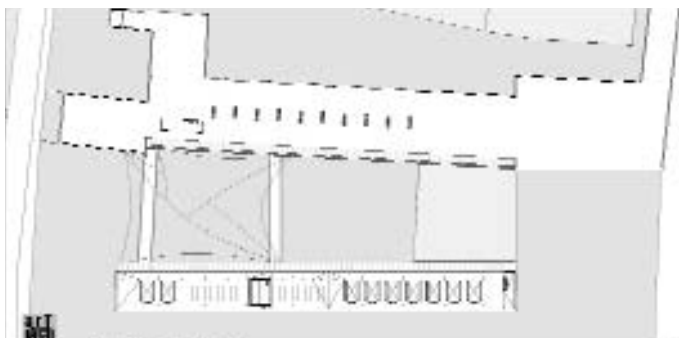

planta cuarta
fourth floor

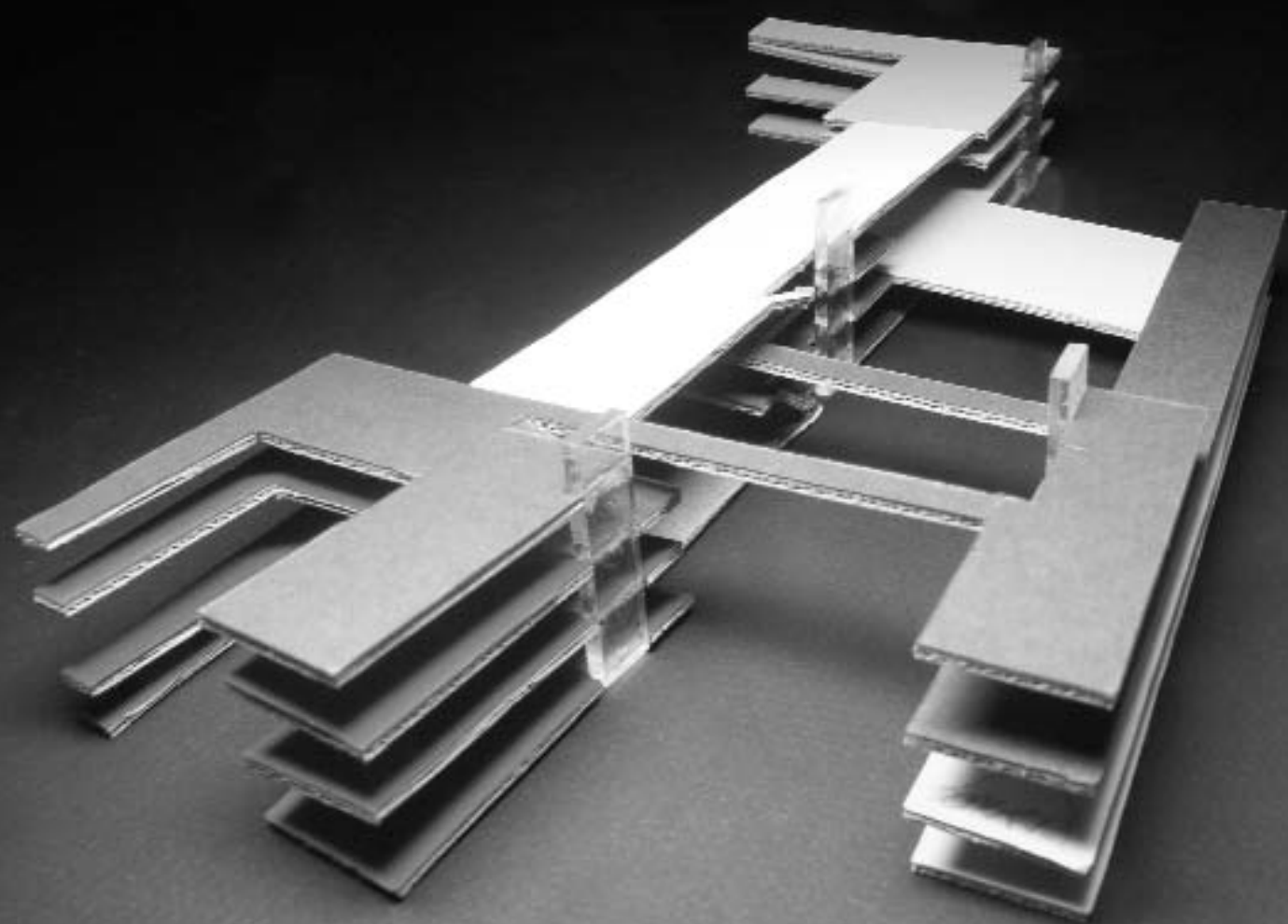
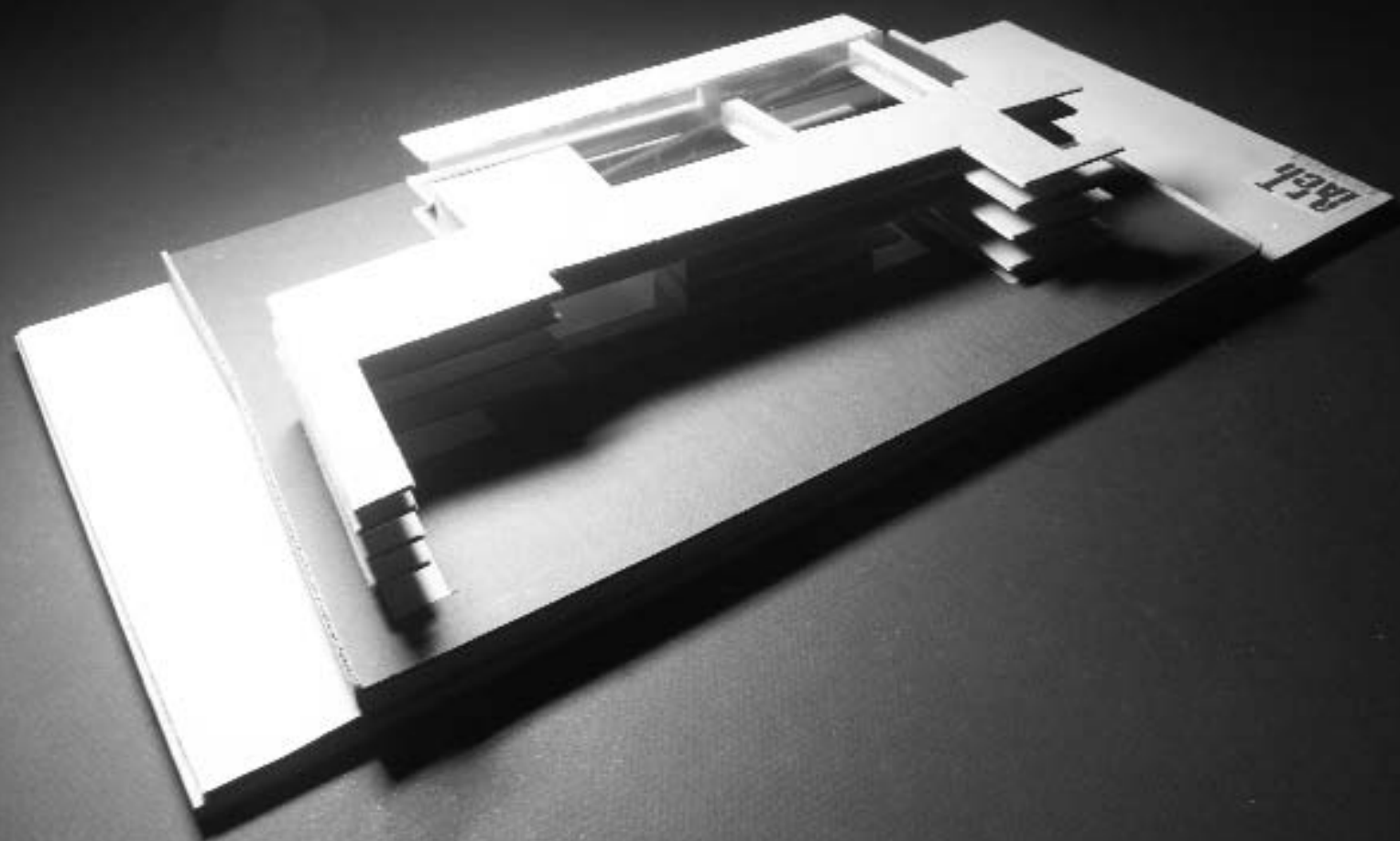

alzado norte
north elevation



alzado sur
south elevation



alzado este
east elevation



sección transversal 1
transversal section 1

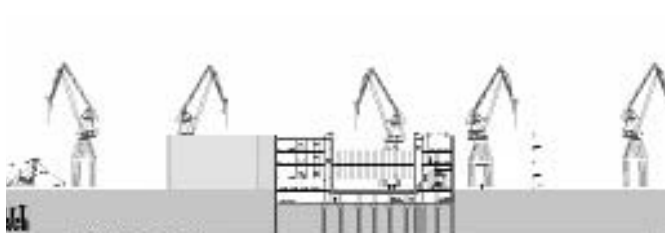

sección transversal 2
transversal section 2

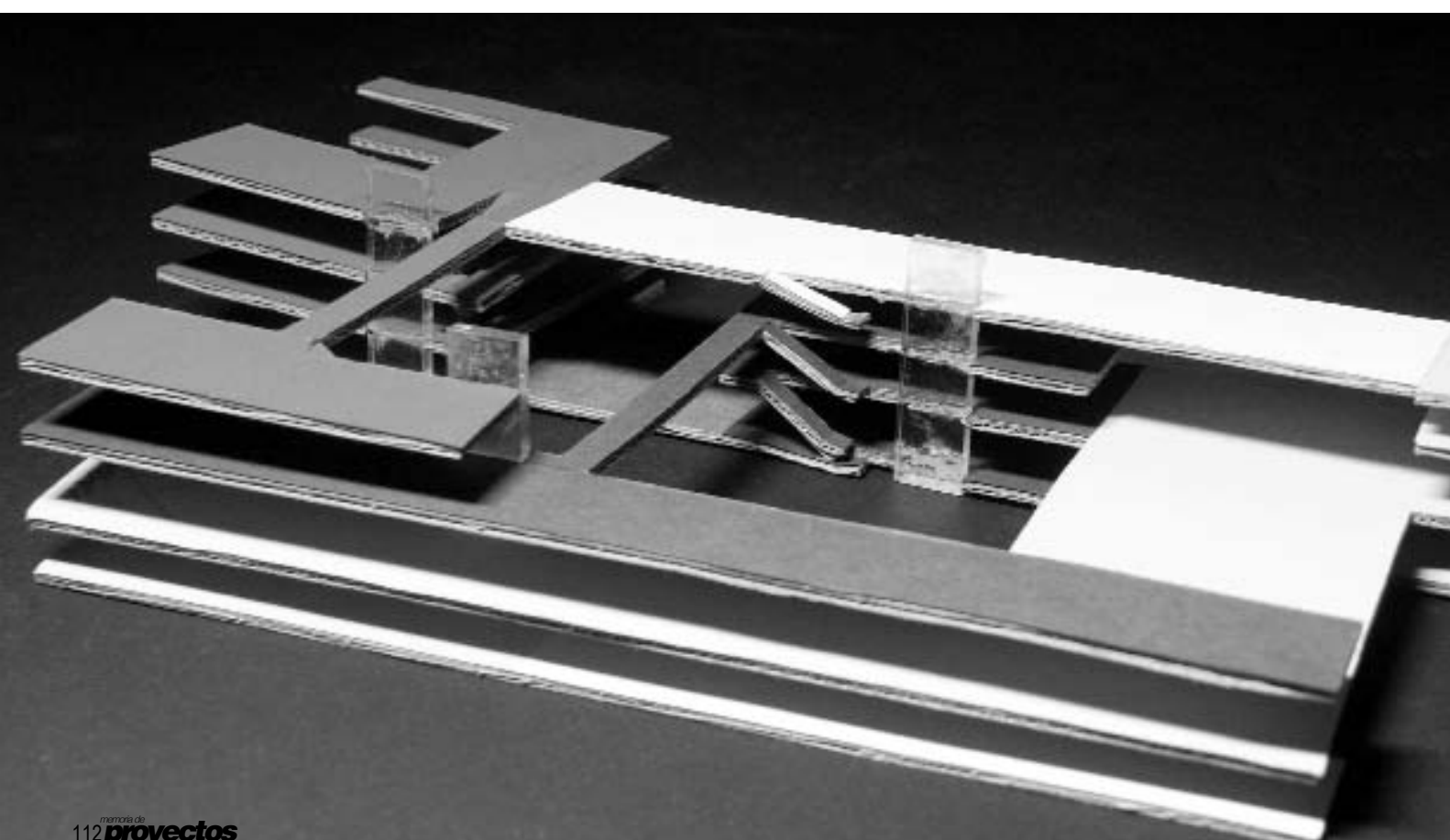
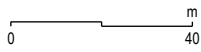
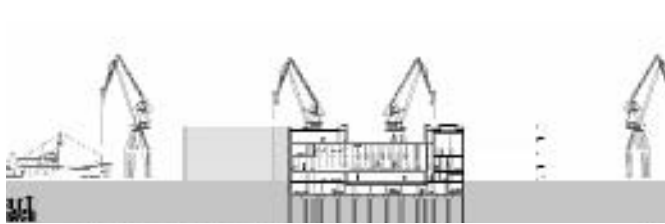

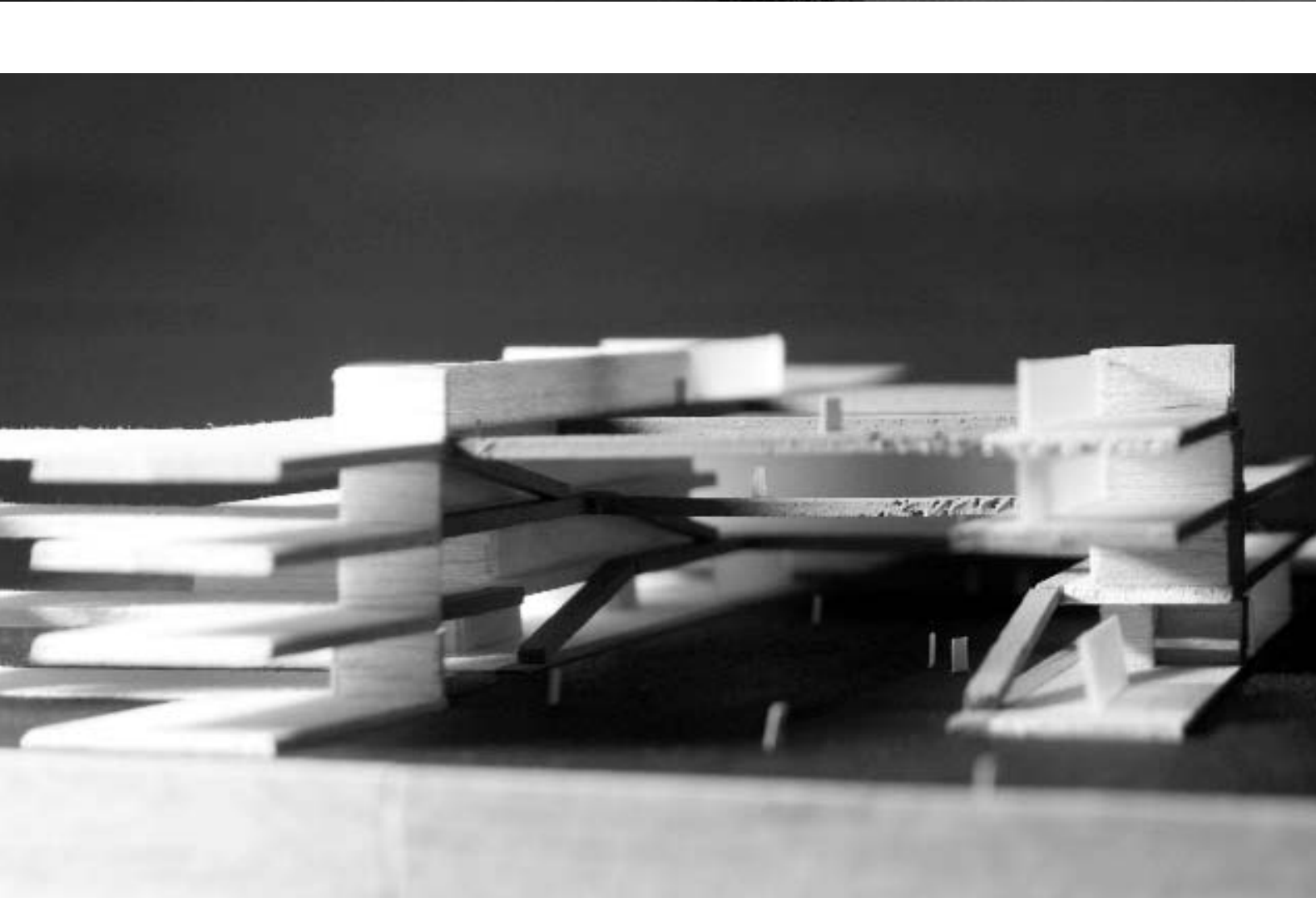
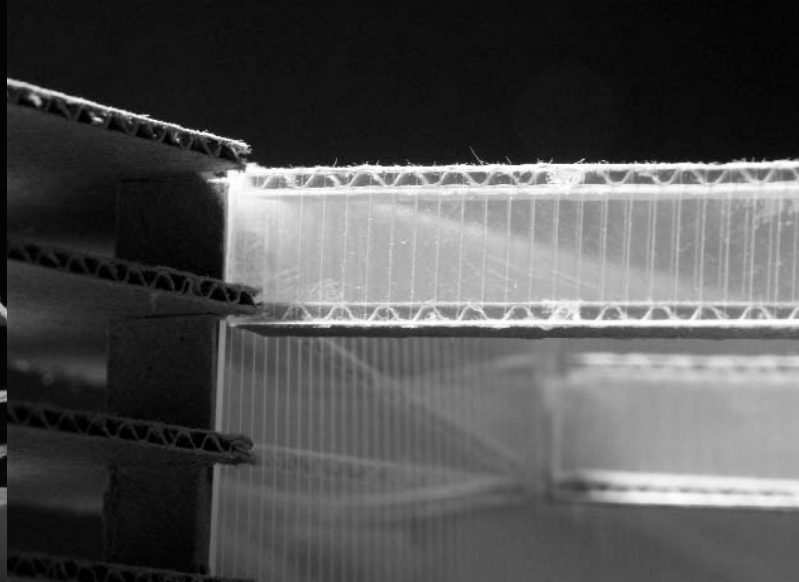
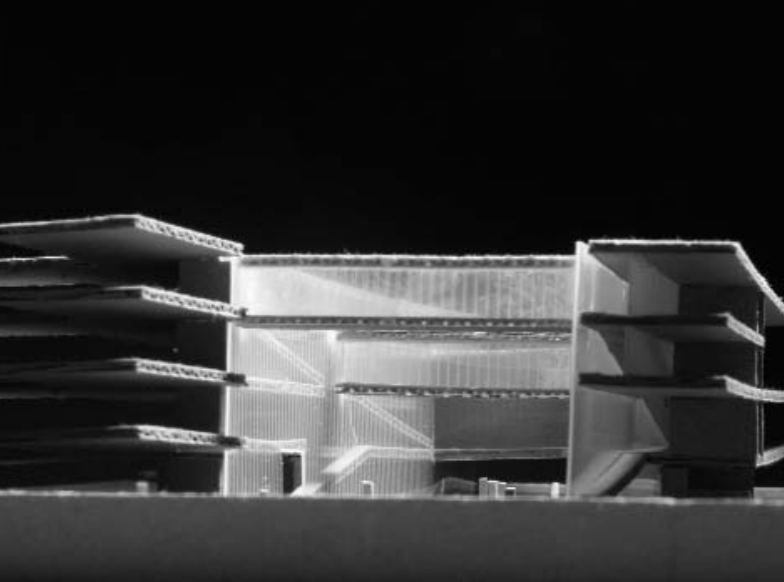
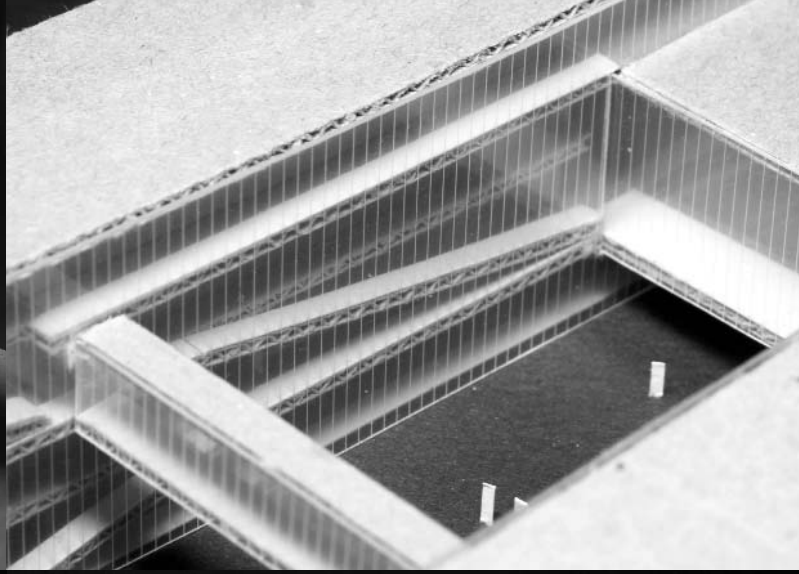
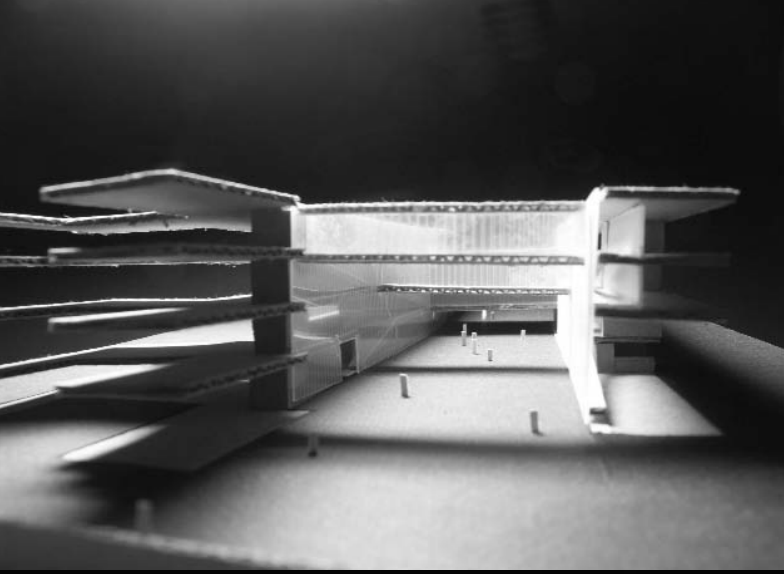

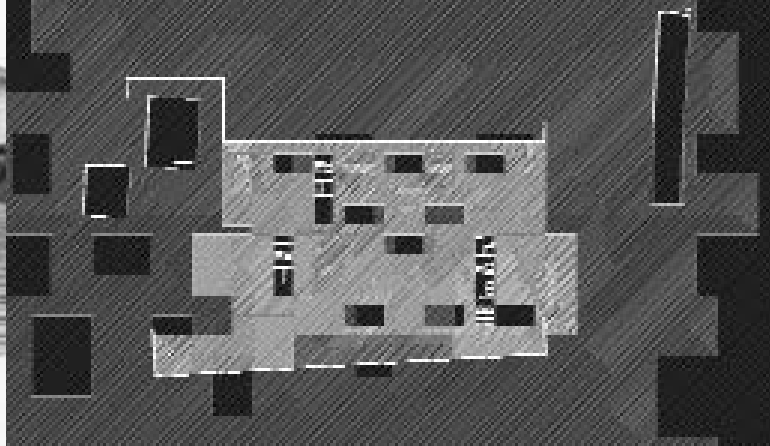

escuela de diseño textil y moda en el entorno de la ría de Bilbao

school of textile and fashion design in the area of the ría de Bilbao

PAULA GARATEA

BILBAO FABRIL

Montaña de hierro sobre el mar. La era industrial comienza en Bilbao en el siglo XIX, como mecanización de los métodos tradicionales de elaboración. Los altos hornos dan riqueza al lugar y conforman una cultura del hierro en el paisaje a cielo abierto de la ría. Pero del hierro y el aire en un afirmarse de las fuerzas elementales. Es la Vizcaya mestiza de la industrialización.

BILBAO MARÍTIMO

Boca larga del río que se hace ría. Todo puerto es una ventana o puerta, que convierte el lugar no en un territorio, sino en un umbral. Tierra sin territorio, lugar de paso, tradición naval, nomadismo. La ría es una frontera que incita a moverse, a traspasar, es la cañada del hierro.

NUEVO BILBAO

Siglo XXI que asoma entre yacimientos de arqueología industrial. Nuevas necesidades y modos de vida que dan lugar a nuevos equipamientos e infraestructuras. Arquitectura, Hierro, Jazz, Astilleros, Cines, Industria, Música, altos hornos, ría, comunicaciones, moda.

USOS:

El proyecto está formado por seis tramas horizontales (telas) que se superponen para formar una urdimbre tridimensional. Cada nivel contiene un uso principal y una serie de usos comunes y de servicio. En general, los espacios abiertos y de uso común se orientan al sur y vuelcan sobre el espacio urbano generado por el propio edificio. Los usos principales y de carácter más privado (aulas, talleres, habitaciones...) se distribuyen a lo largo del telar abriéndose a diferentes patios. La parte orientada al norte y que coincide con el lugar de paso de la vía rodada, se deja para los usos de servicio o necesidades más específicas que requieran iluminación más uniforme (biblioteca).

COMUNICACIONES:

El edificio queda cosido por tres núcleos estructurales ciegos que albergan las comunicaciones verticales, instalaciones y locales de servicio. Cada uno de ellos se asocia principalmente a uno de los niveles: residencia escuela y pasarela.

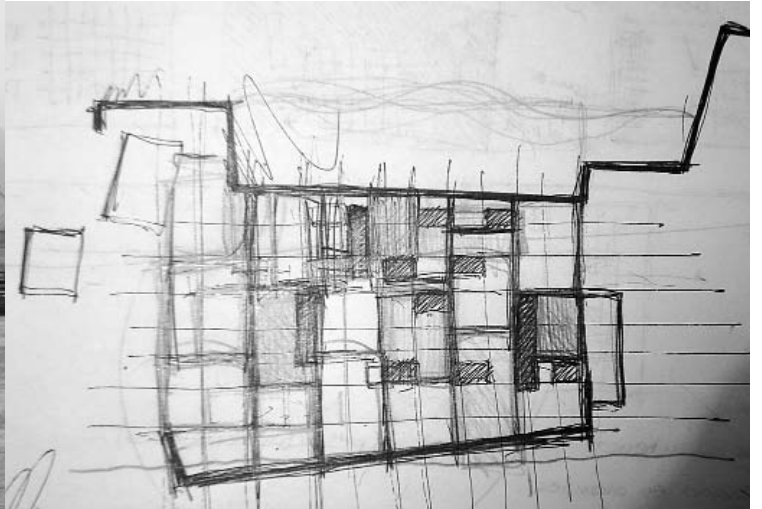
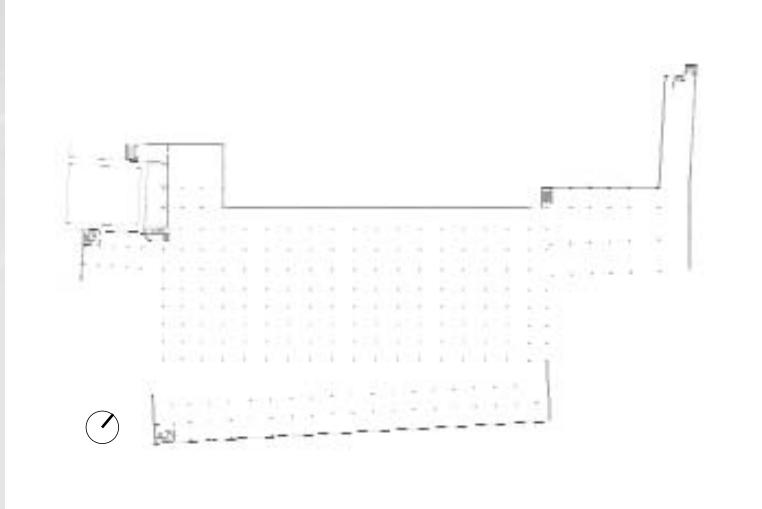

INDUSTRIAL BILBAO

A mountain of iron on the sea. The industrial era began in Bilbao during the 19th century as a way of mechanising traditional production methods. The blast furnaces lend richness to the area and create a culture of iron in the landscape, which is open to the Ría. Iron and air which substantiate the force of the elements. This is the hybrid Vizcaya of industrialization.

MARITIME BILBAO

The long mouth of the river which flows into the ría. Each port is a window or a door, transforming the area not into a territory, but a threshold. A land with no country, a place of passage, naval tradition, nomadic convention. The ría is a frontier which invites us to move, overstep... it is the iron ravine.

NEW BILBAO

The 21st century peeks out from among industrial archaeological sites. Contemporary needs and ways of life lead to new equipment and infrastructures. Architecture, Iron, Jazz, Shipyards, Cinemas, Industry, Music, Blast Furnaces, Ría, Access, Fashion.

USES:

The project comprises six horizontal weaves (cloths) which are superimposed in order to create a three-dimensional warp. Each level has its primary use and a series of common, service functions. In general, the open common areas are south-facing and give onto the urban space generated by the building itself. The primary uses, together with private functions (classrooms, workshops, rooms...) are distributed throughout the fabric, opening onto different patios. The north side, which coincides with the passage of the road, is conceived of for service uses and for more specific needs which require uniform lighting (library).

ACCESS:

The building is united by three blind structural nuclei which house vertical access, installations and service premises. Each is associated to one of the levels in particular: residence-school and passageway.



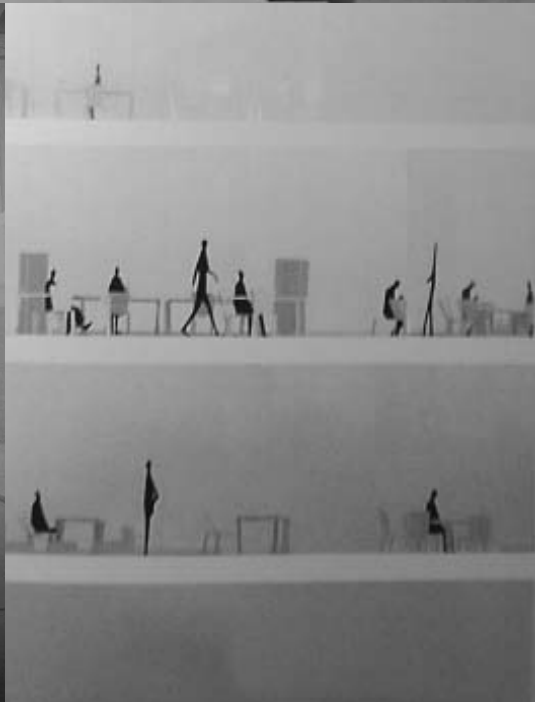
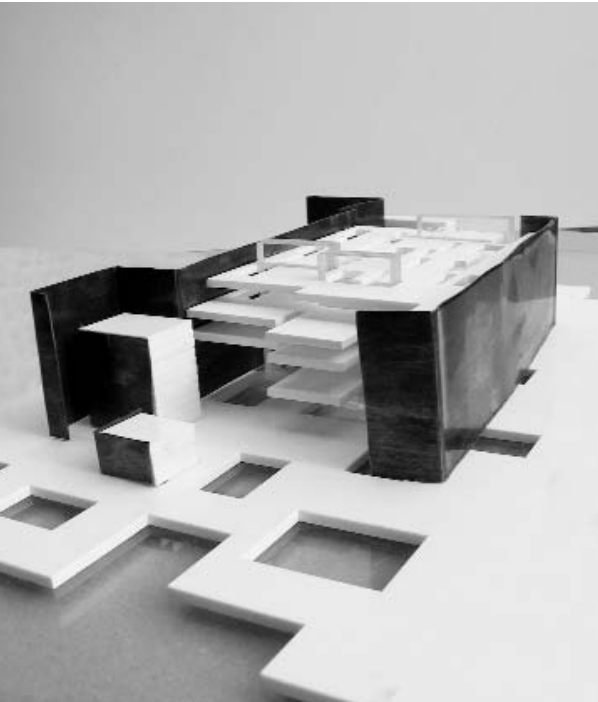
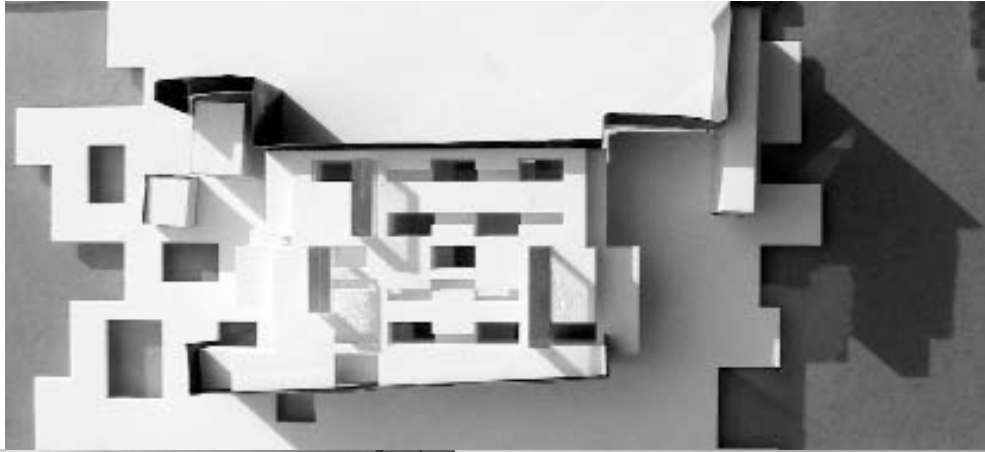
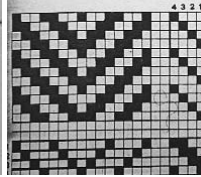
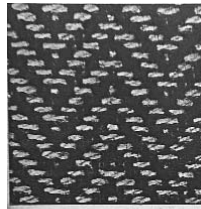
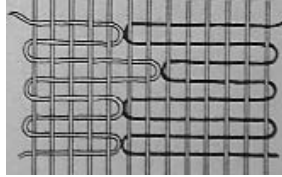
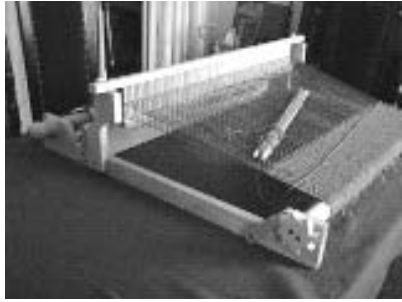



alzado suroeste
southwest elevation

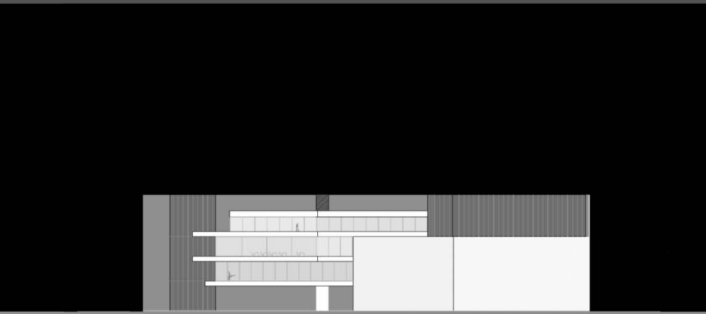

alzado noreste
northeast elevation

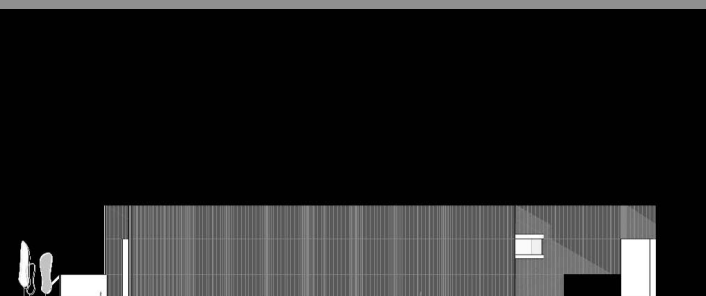

alzado sureste
southeast elevation

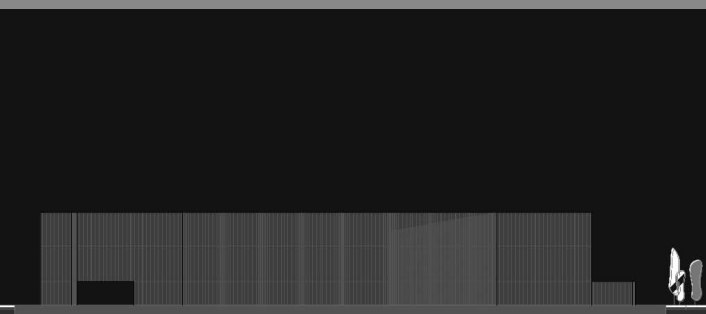

alzado noroeste
northwest elevation

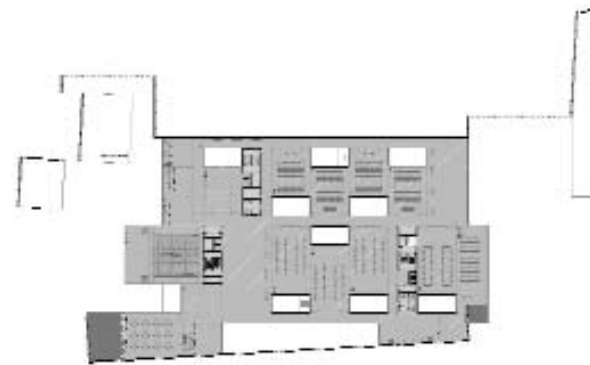

planta primera
first floor



planta segunda
second floor

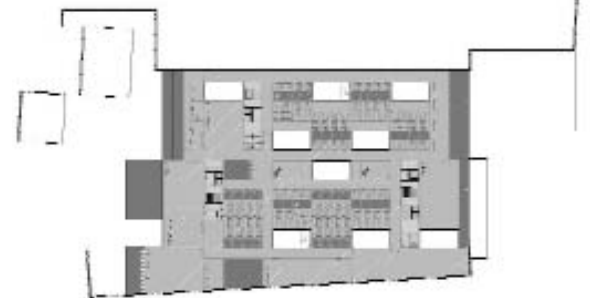

planta tercera
third floor

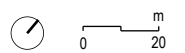



sección 1
section 1

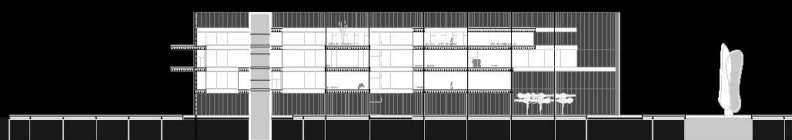

sección 2
section 2

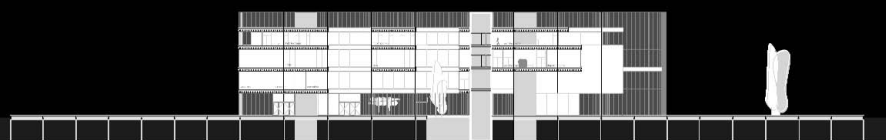

sección 3
section 3

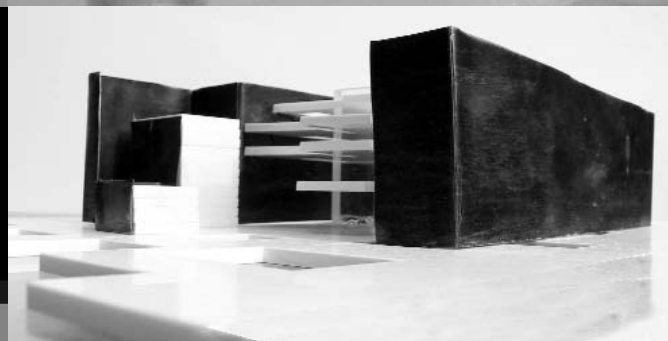

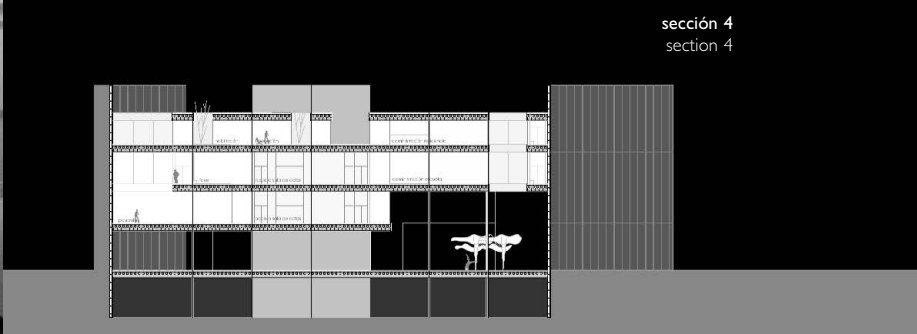
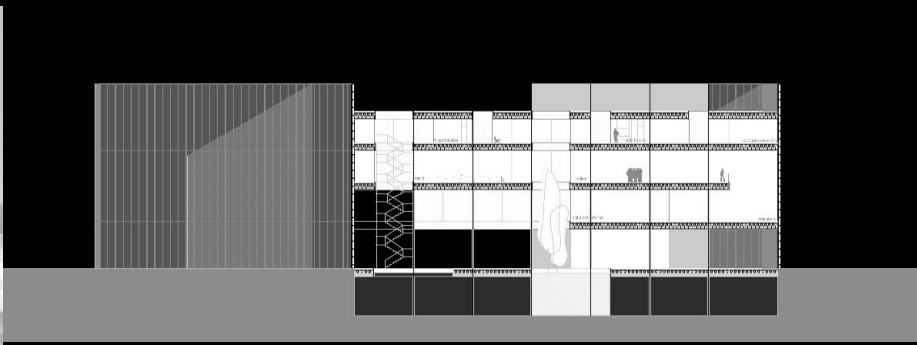
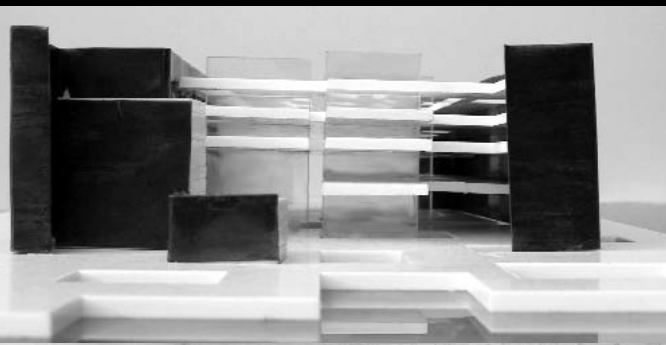

sección 4
section 4

sección 5
section 5

0 ——— m
20

sección 6
section 6



centro cultural en san sebastián

cultural centre in san sebastian

FRANCISCO CALLEJA DELGADO

El solar de forma poligonal y de dimensiones 140x120 metros aproximadamente se encuentra ubicado junto al club de tenis de San Sebastián, en la playa de la Concha. Por tanto su ubicación está junto al paseo marítimo. A mi entender el paseo tiene un principio en la plaza del ayuntamiento y su terminación se materializa con la obra de Chillida "el peine de los vientos". Debido a la ubicación del solar, entiendo que debe tener un carácter "de paso". Por ello el edificio en su planta de acceso albergaría todos los usos públicos mientras que en la planta superior, mas fragmentada albergaría el resto de usos propios de este tipo de edificios. Se muestra compacto, definido, y con presencia, de volumetría definida. Debe tener presencia, personalidad y una imagen reconocible de su carácter público y actividad abierta. Se trata de un prisma casi perfecto que se relaciona de forma adecuada con la escala del lugar. En el prisma se producen una especie de pliegues-hendiduras para introducir luz en el interior y que a la vez divide al edificio en tres partes diferenciadas por cuestiones de uso (salón de actos, espacio central, pista cubierta). Debido a la visión panorámica, la cubierta de éste es tratada como la quinta fachada. Tanto la cubierta como gran parte del cerramiento vertical se materializa en base a un mismo concepto, una piel plegada de chapa perforada que protege del exterior y bajo la cual "ocurren cosas" pero que también tiene la capacidad de controlar la LUZ y mantener un carácter ambiguo del edificio entre interior-exterior. Durante el día el edificio se manifiesta rotundo, compacto, oscuro, mientras que en la noche es una "linterna" que ilumina y que delata su posición.

The polygonal lot measuring approximately 140x120 metres is located next to the San Sebastian tennis club on La Concha beach, adjacent to the esplanade. As far as I understand, the seafront begins at the town hall square and ends where Chillida's "Wind Combs" are displayed. Due to the location of the lot, it seems as though it should be an area of passage. For this reason, the ground floor of the building would house public uses, while the upper floor, which is more fragmented, would be reserved for uses typical of this type of buildings. It is compact and defined, with a great presence and defined volumetry. It should have presence and personality, as well as a recognizable image as a public building open for activities. It is nearly perfect prism which sits in appropriate relation to the scale of the area. The prism is cut by a series of folds or clefts, through which light can reach the interior, while at the same time dividing the building into three separate parts, each with a different use (auditorium, central area, covered area). Due to the panoramic vision, the roof is considered a fifth façade. Both the roof and a large part of the vertical enclosure are based on a common concept: a folded skin of perforated sheet metal which protect it from the outdoors and under which things happen; it likewise serves the purpose of controlling the entrance of LIGHT, and maintains an ambiguous feeling in the building between indoors and out. During the day, the building is emphatic, compact and dark, while at night it becomes a "torch", illuminating and disclosing its location.

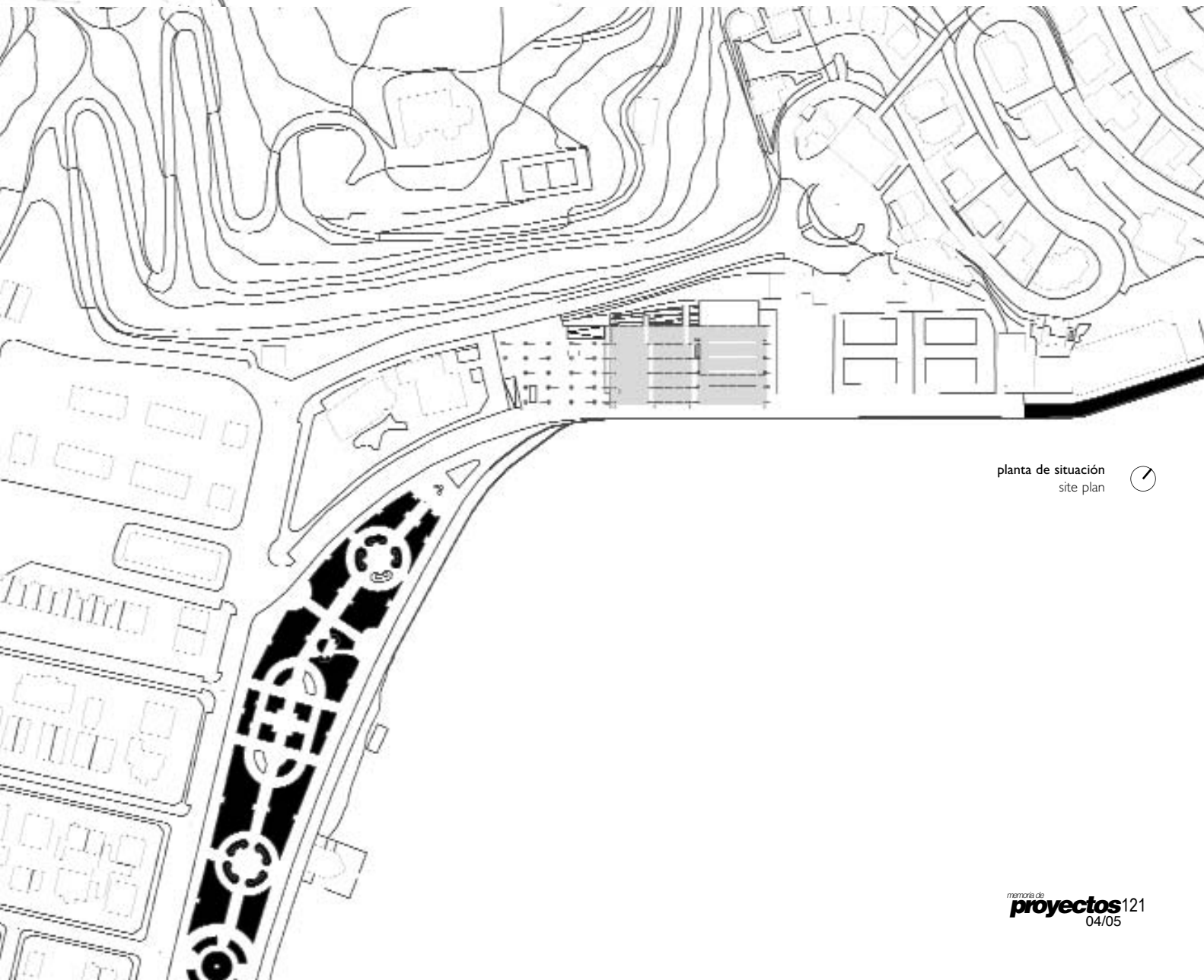
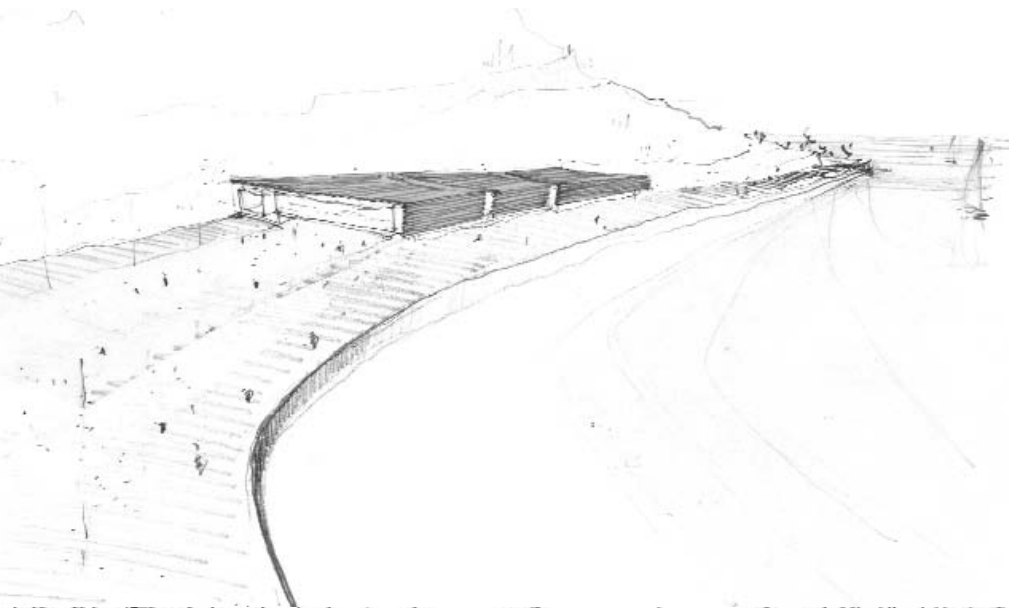

planta de situación
site plan



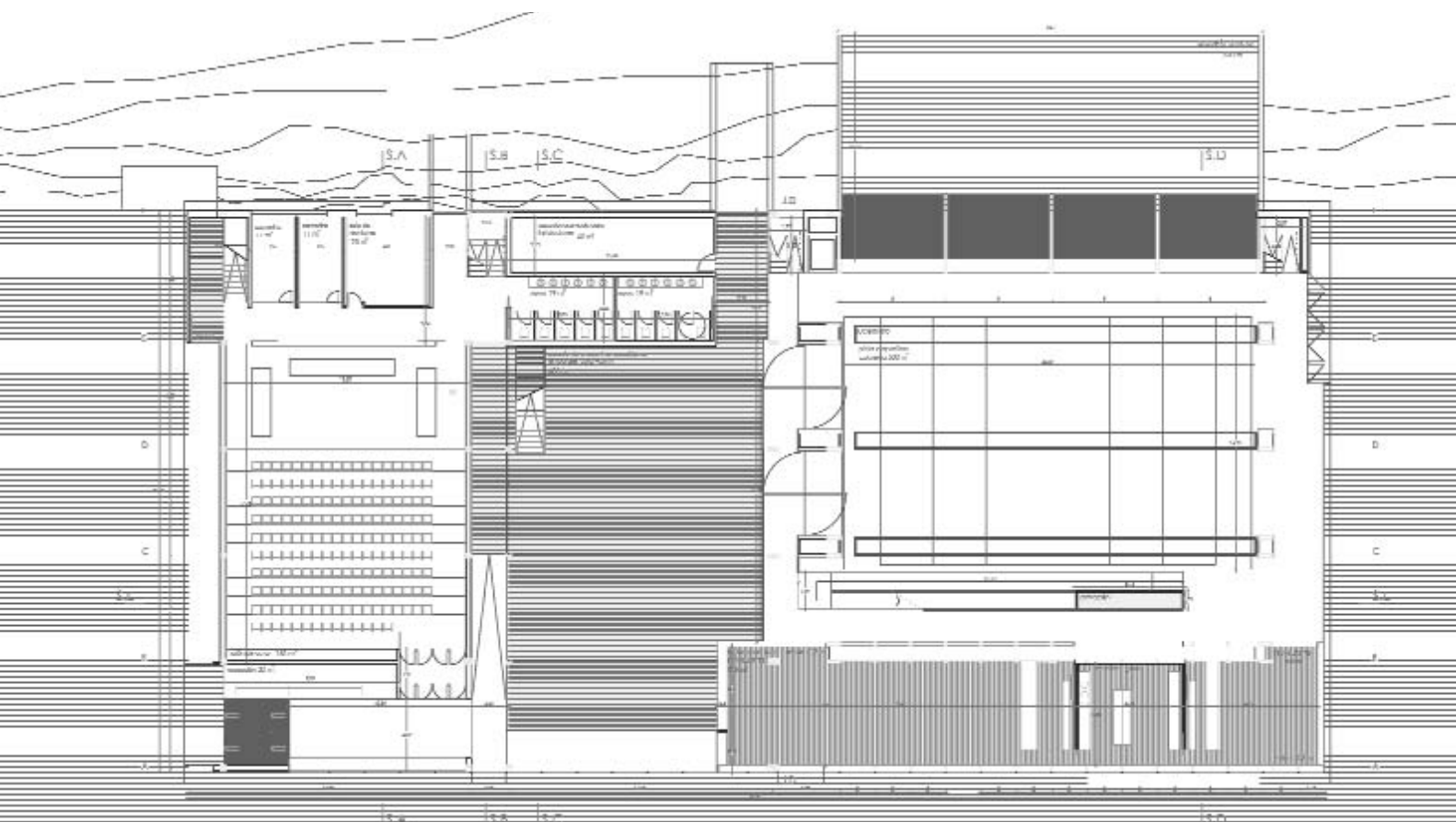

planta general
main plan

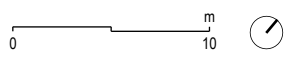

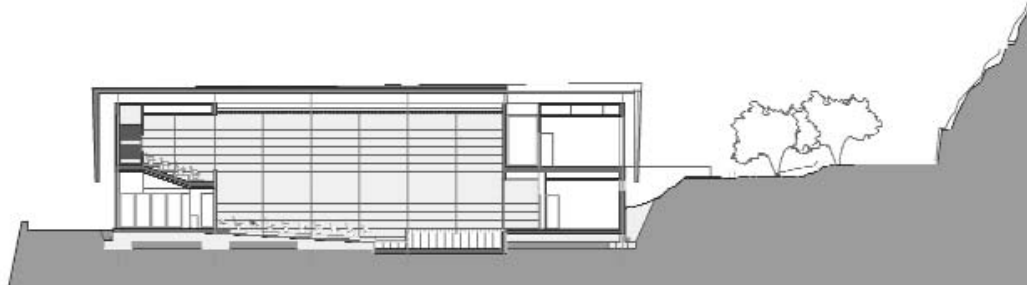
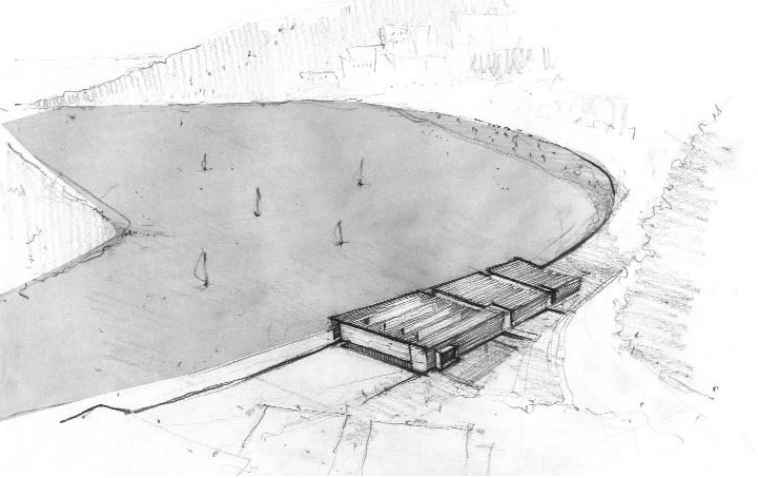

sección A
section A

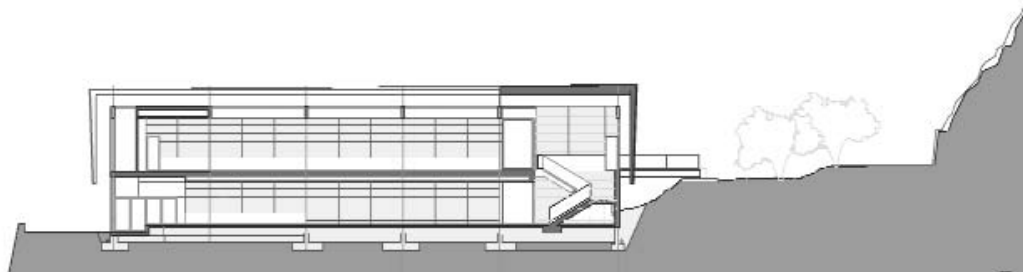

sección B
section B

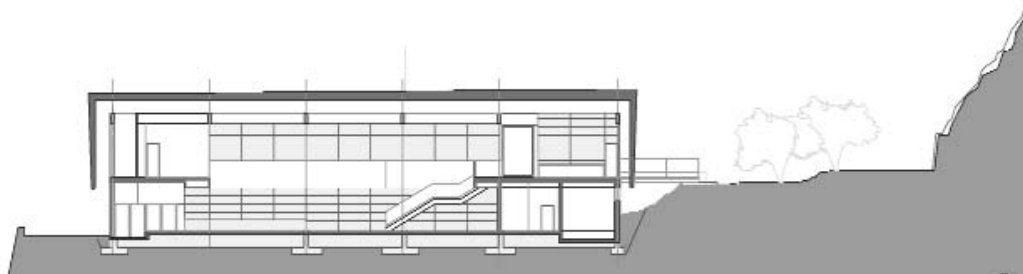

sección C
section C

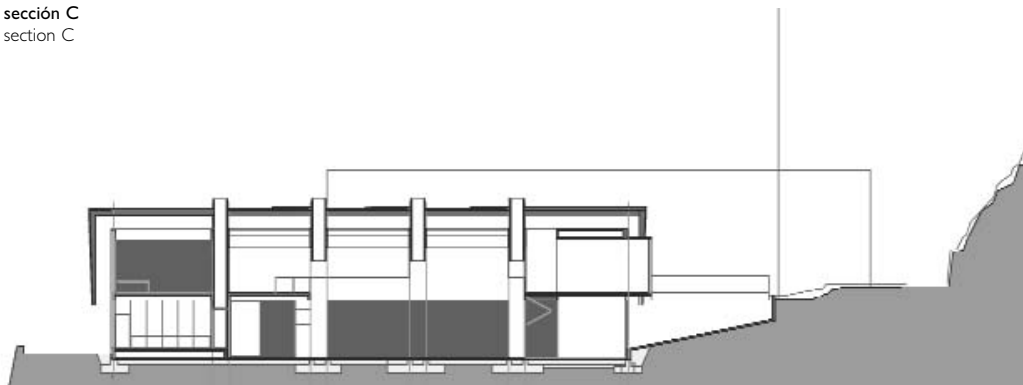

sección D
section D

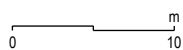

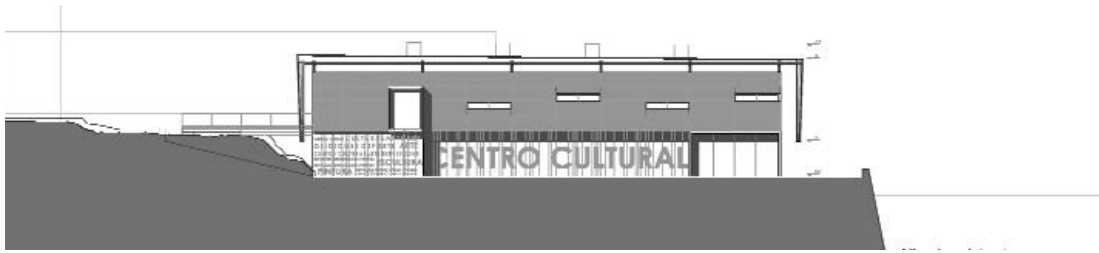

alzado sur
south elevation

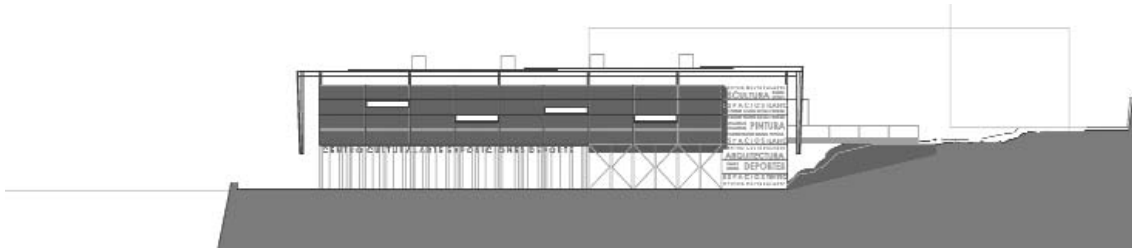

alzado norte
north elevation

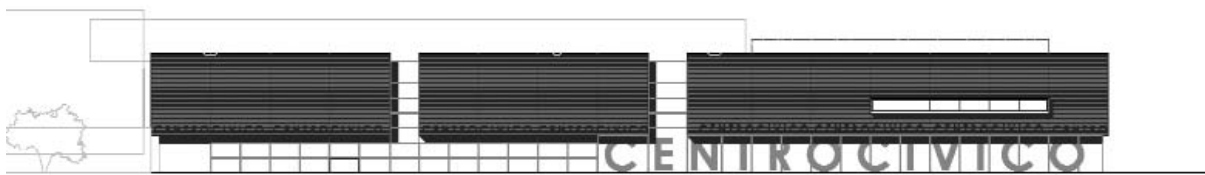
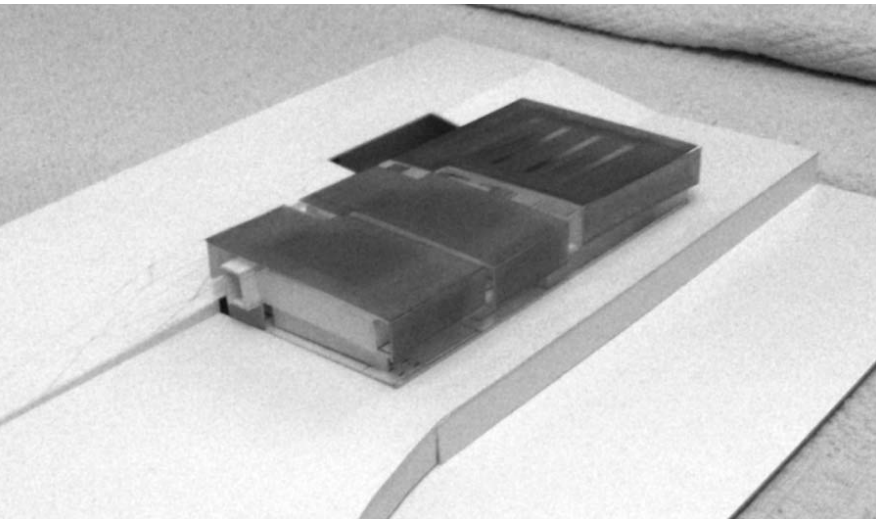

alzado este
east elevation



alzado oeste
west elevation

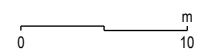

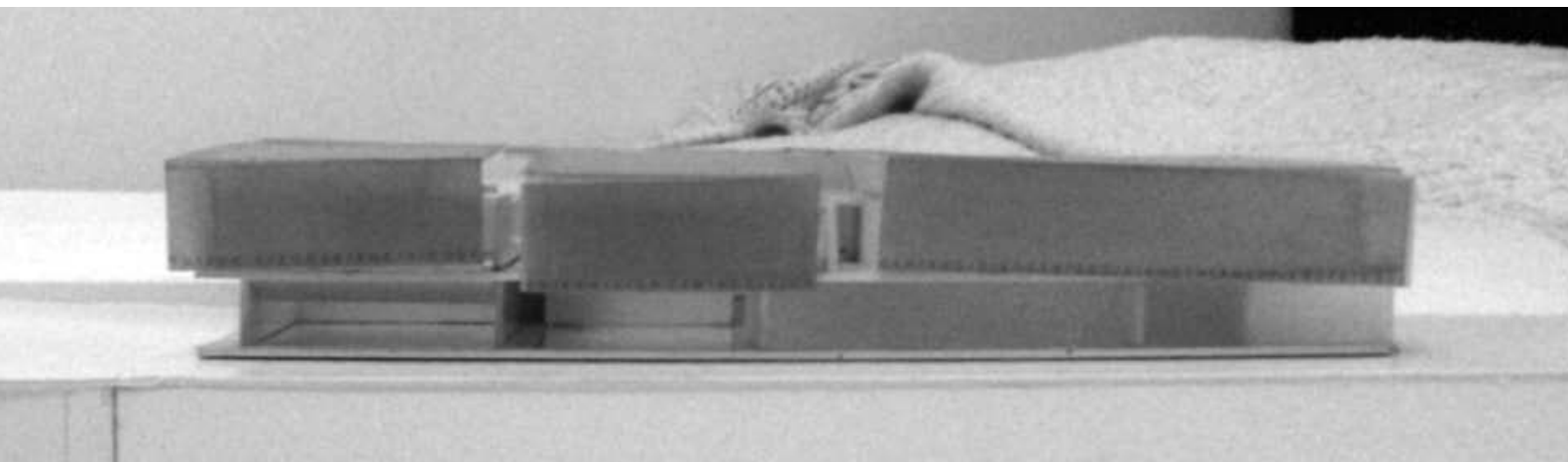
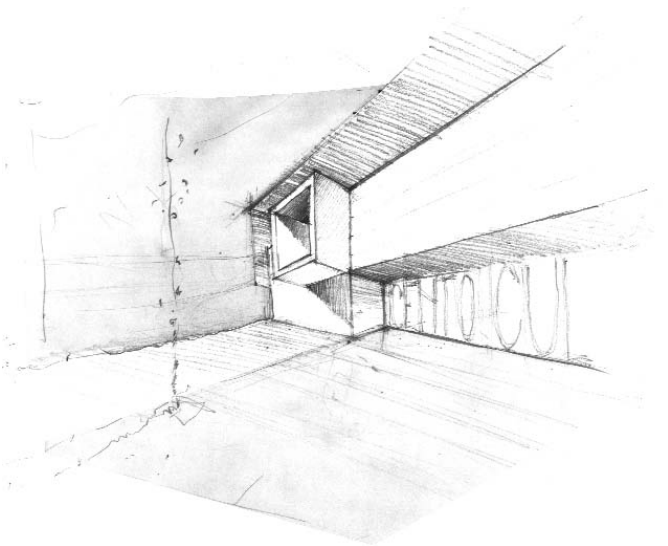
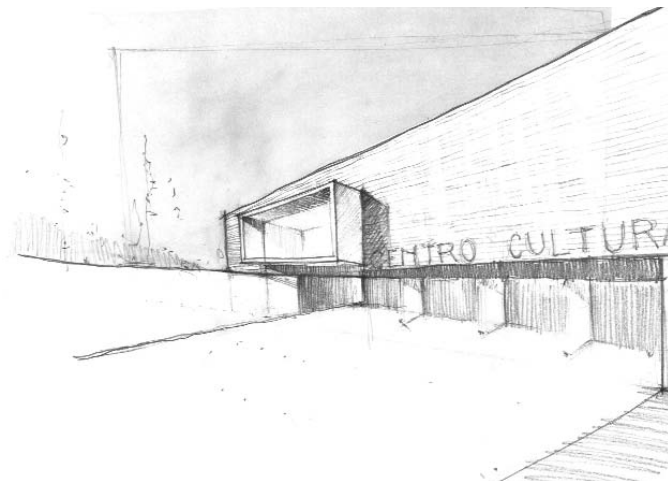
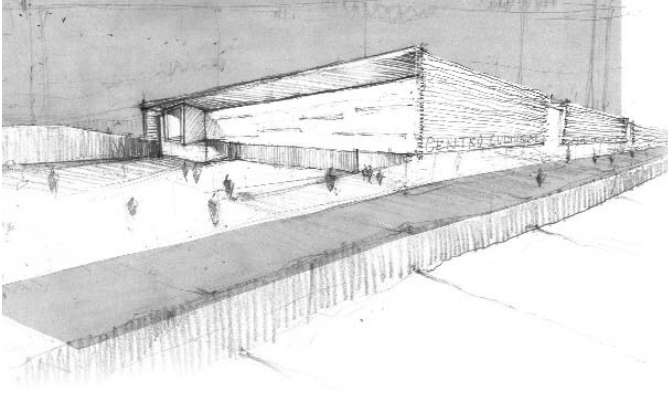



teatro/hotel/kukuxumusu design center/vivienda

theatre/hotel/kukuxumusu design center/residences

JORGE LOSADA

La actuación se localiza en el centro de Pamplona, en un lugar ambiguo que pertenece al casco histórico y al ensanche al tiempo. Pretende intensificar la actividad en la zona y paliar así la descentralización y el deterioro de la trama urbana provocada por la oferta periférica. Se configura como un espacio de alternativas que enlaza mediante un vacío ambos tejidos, que no pretende competir con la Plaza del Castillo, sino complementarla con una oferta cultural renovada, un teatro, un espacio comercial, viviendas y un hotel. Un espacio de sombra con un bombardeo incesante de estímulos de toda índole. El comercio y las viviendas, una unidad volumétrica, se acodan contra el ensanche, cerrando el espacio principal y generando un filtro muy permeable. El Kukuxumusu Design Center ofrece opciones de compra variadas, desde el comercio masivo en un espacio sin fin, a las compras pausadas con espacios de estancia, cafetería y proyecciones. Las viviendas se orientan a la gente joven con objeto de rejuvenecer la población y reactivar la zona, flexibles y libres aceptan diferentes configuraciones. Hotel y teatro se apoyan en la trama histórica y renuevan el remate de la emblemática Estafeta. El primero genera un espacio vertical que deviene en una última planta diáfana. Con una volumetría tensionada que facilita una correcta iluminación de las calles, asociándose al resto de la manzana para generar una unidad. La tersa piel de vidrio presenta una fenestración intensa que busca el lujo en los diferentes modos de mirar la calle y el encierro. El teatro juega con la ilusión y el desequilibrio, caracterizando con una gran masa en vuelo el espacio público y fundiéndose con él. Subrayando la ilusión de las representaciones, generando un corazón de madera donde se produce la comunicación. Una estructura de principios sencillos aunque implicada formalmente rige el orden que se seguirá hasta los detalles constructivos

Our programme is located in the centre of Pamplona, in an ambiguous area pertaining both to the historical centre and to the new suburbs. The idea is to intensify activity in the area, thus mitigating the decentralization and deterioration of the urban centre generated by offers available in the outlying areas. It is conceived of as an area of alternatives which would link both sections by means of a void, with the intention not of competing with the Plaza del Castillo, but rather of complementing it through a renewed cultural programme, a theatre, a shopping area, residences and a hotel. An area in the shadows which would be constantly bombarded with stimuli of every sort. The shopping area and the flats, a large volumetric unit, back up to the suburbs, closing the main area and generating a highly permeable filter. The Kukuxumusu Design Centre offers various shopping options, from orders in bulk in an enormous space, to individual purchases in an area with shelves, a cafeteria and various projections. The flats, free and flexible with possibilities for different set-ups, are conceived of for young people with the aim of bringing new youth to the population and jump-starting the area. The hotel and the theatre are located towards the historical area and round off the emblematic Estafeta. The first generates a vertical space which is crowned by an open-plan top floor. With a tense volumetry which aids in the proper illumination of the surrounding streets, it ties in with the rest of the city block to create a unit. The smooth glass skin offers an intense window arrangement which provides a luxury view through its different manners of looking onto the street and the enclosure. The theatre plays with a combination of illusion and imbalance, characterizing and blending into the public space through an enormous mass in flight. The building underlines the illusion of performance and generates a wooden core where communication occurs. A structure of simple principles which through its formal implications serves as a guide for the order to be followed in the building details.

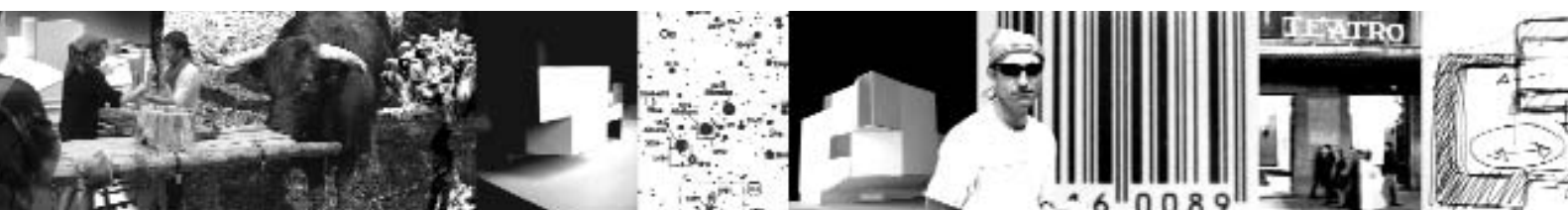

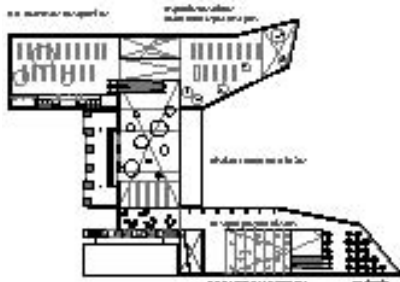
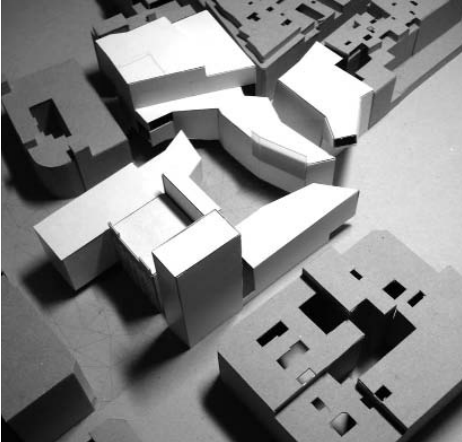

planta primera
first floor

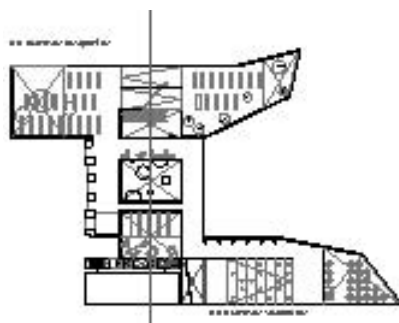

planta segunda
second floor

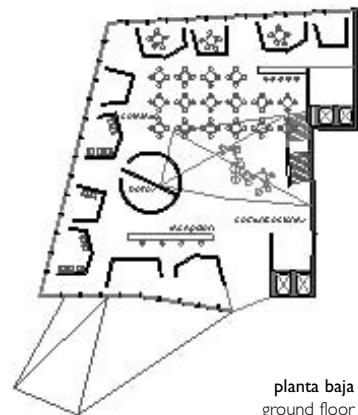

planta baja
ground floor

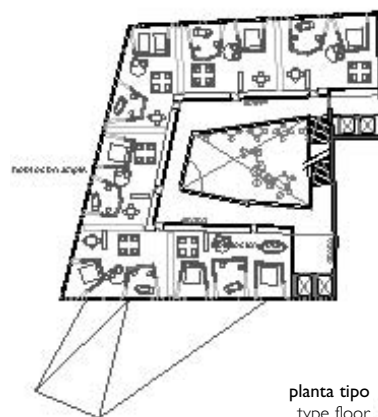

planta tipo
type floor



alzado Cortes de Navarra
elevation Cortes de Navarra



sección longitudinal
longitudinal section

alzado calle estafeta
elevation estafeta street

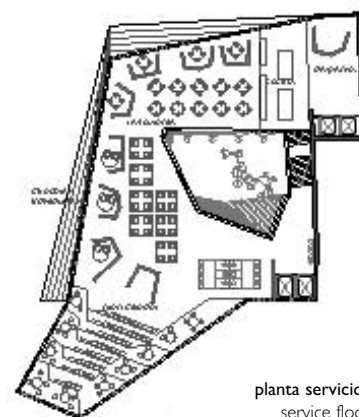

planta servicios
service floor

0 ————— m
10



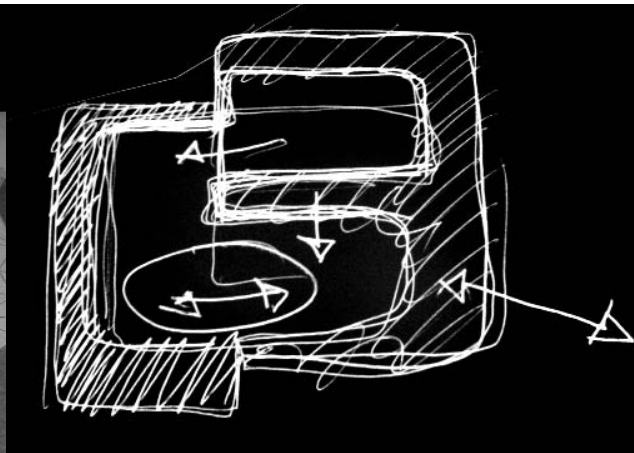
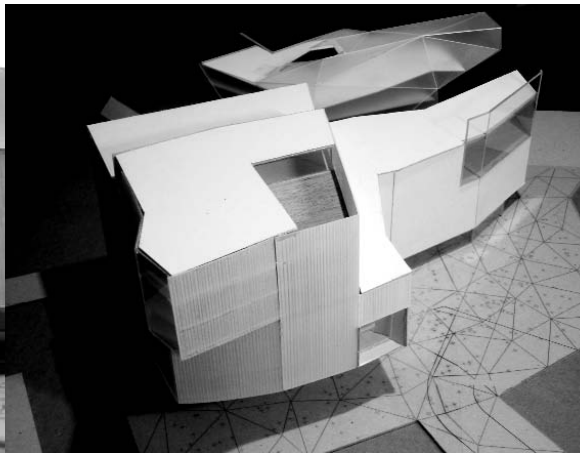
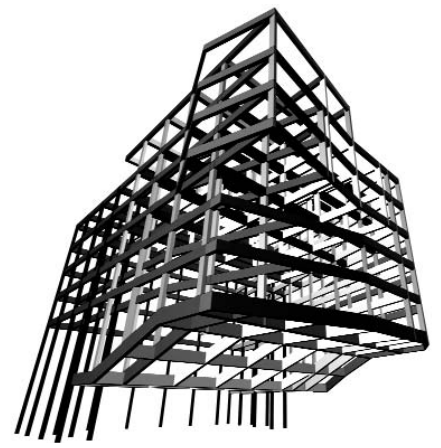

planta baja
ground floor

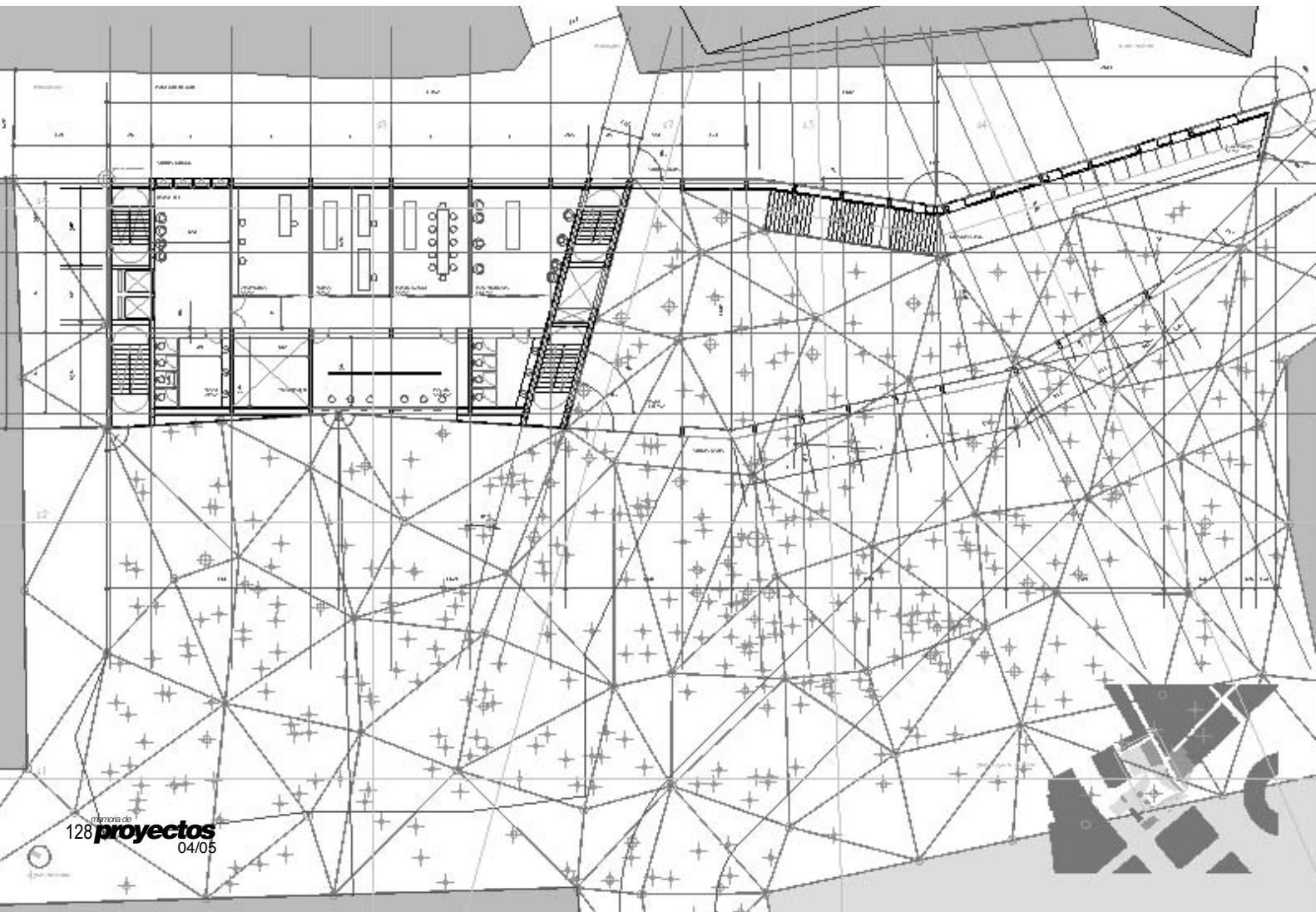
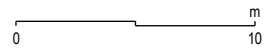

detalle constructivo
constructive detail

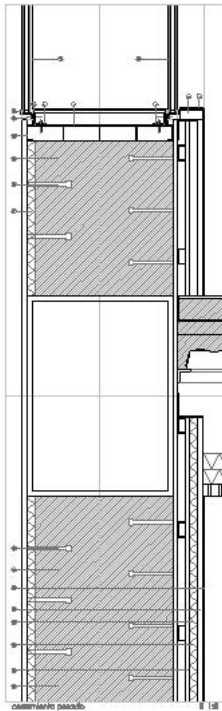

sección longitudinal
longitudinal section

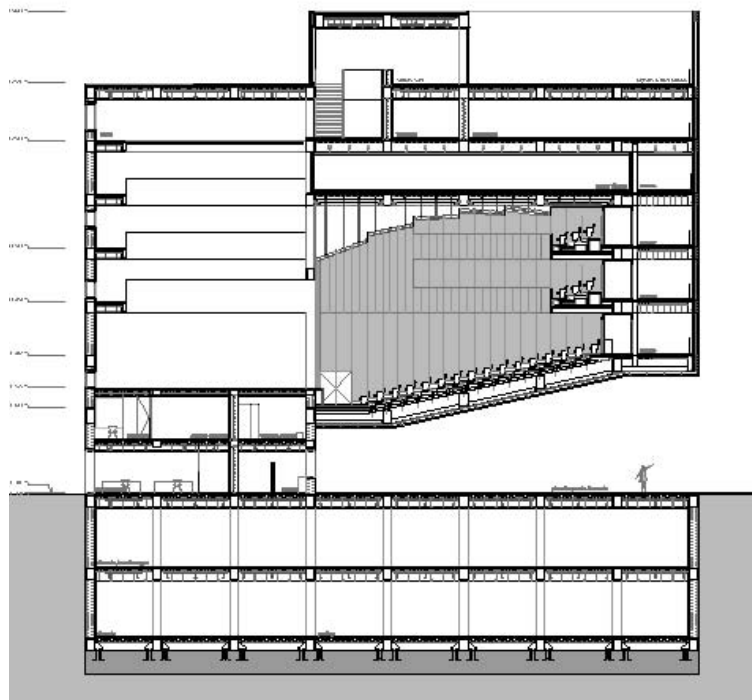

detalle constructivo
constructive detail

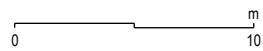
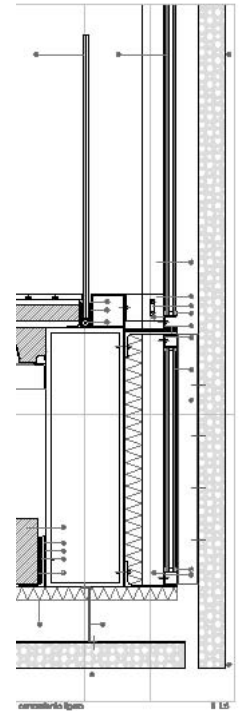

planta aforo teatro
theatre floor

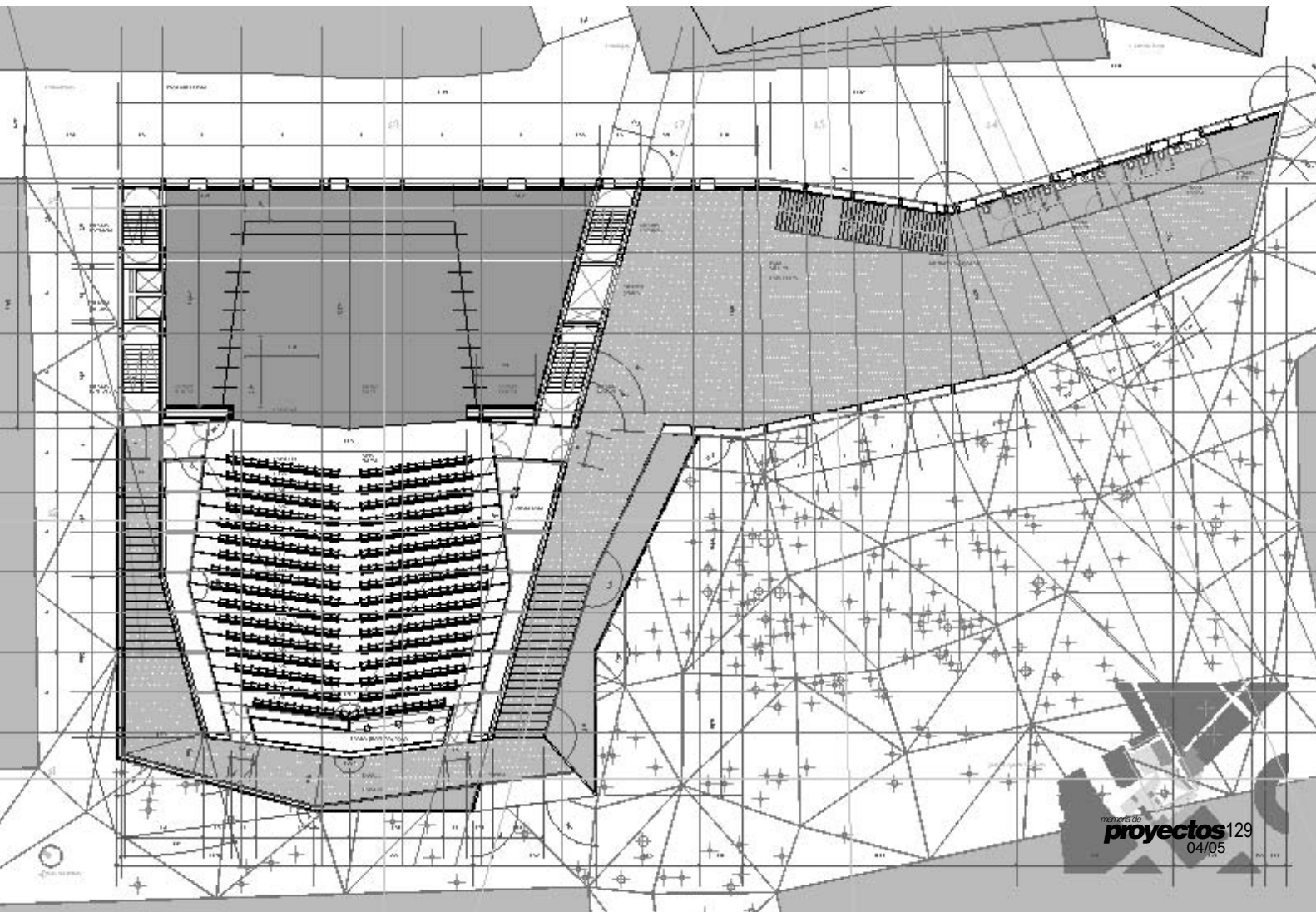



alzado
elevation

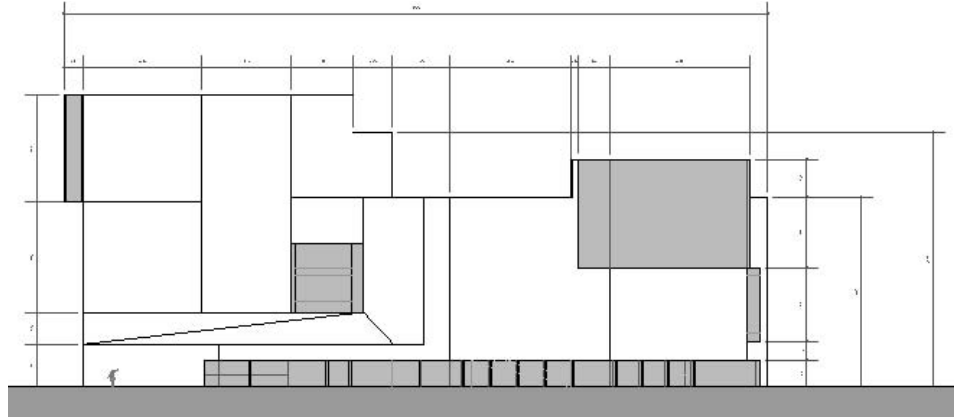

alzado
elevation

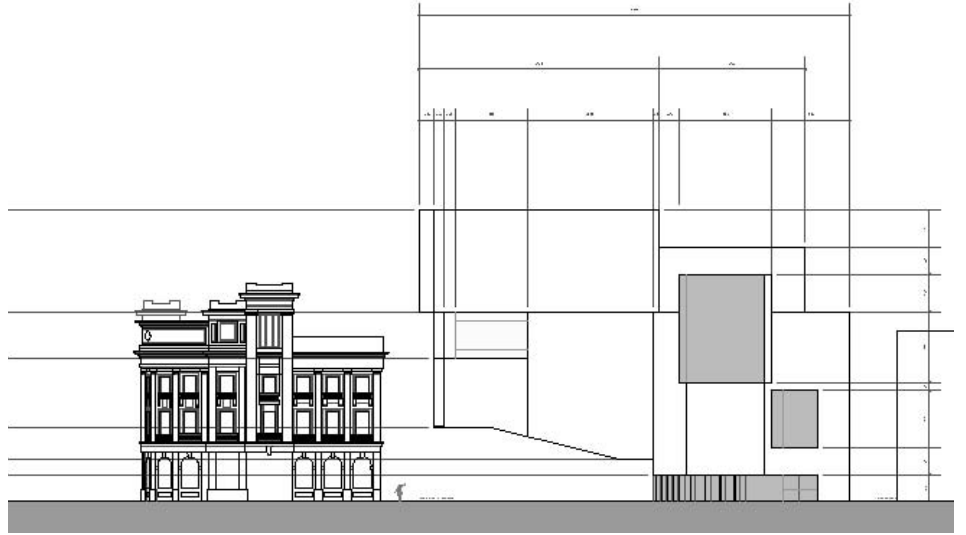

0 20 m
sección longitudinal
longitudinal section

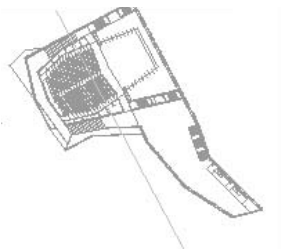
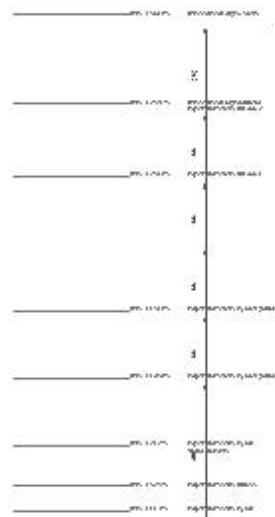
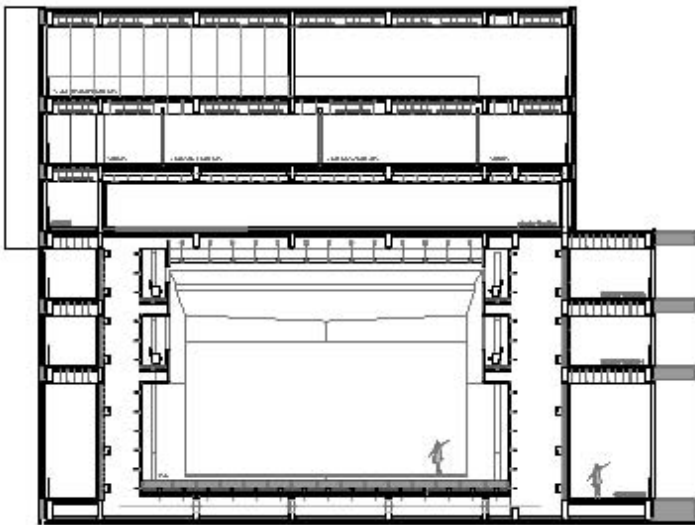

0 10 m



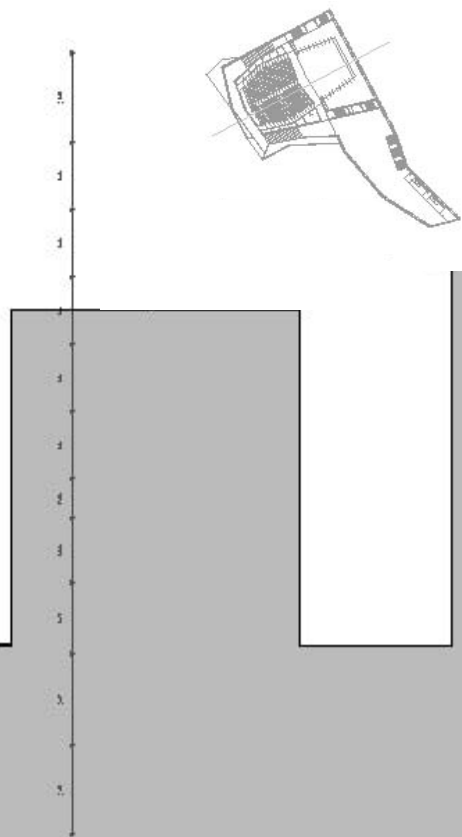
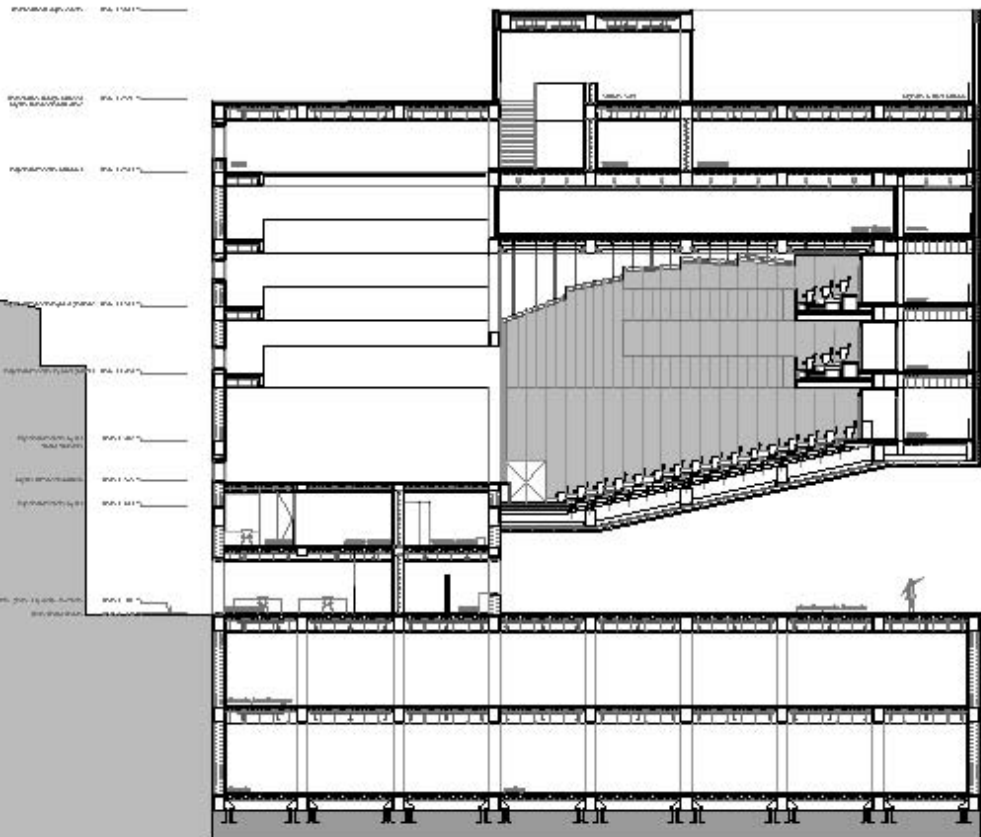
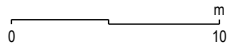
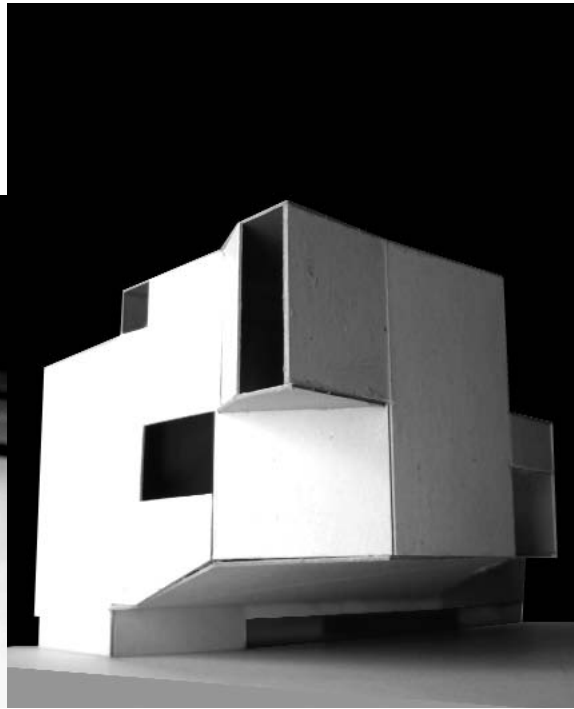
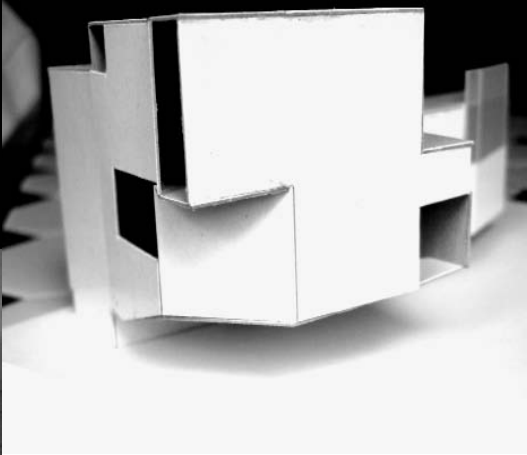
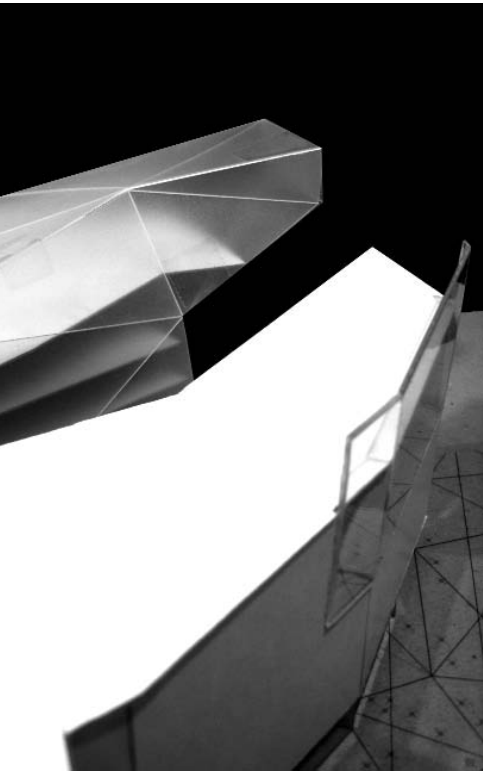

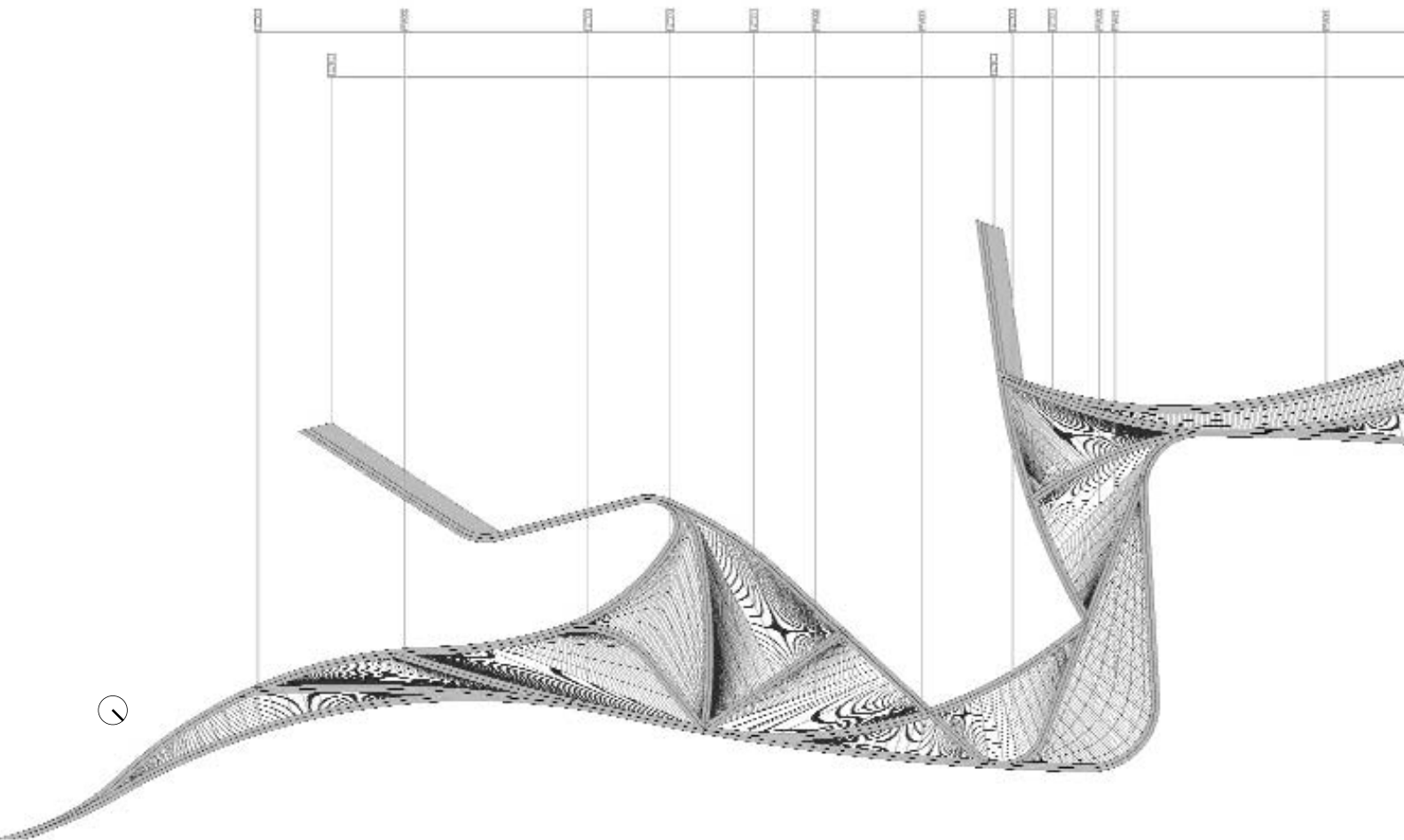

devolución de tierra al mar

returning the land to the sea

BELÉN LABIANO

El proyecto se desarrolla en Getxo, Bizkaia, situado en el margen derecho de La Ría y pertenece al ámbito denominado 'La gran Bilbao'. El punto de partida es un solar ganado al mar para la construcción de unas piscinas, que no funcionó como tierra y se ha convertido en un no lugar. Ésta es la principal razón que explica el deseo de devolver parte de este suelo al mar. Los motivos que llevaron esta intervención al fracaso así como los aspectos positivos que convierten este punto geográfico en un lugar especial pueden deducirse del análisis del entorno: Se trata de un lugar privilegiado por su ubicación en el límite de Getxo con el mar; su proximidad al puerto viejo de Getxo, zona histórica de actividad y el ambiente tranquilo y recogido que se presenta al no ser un punto de paso sino un fondo de saco. Los puntos débiles del solar se deben, entre otras razones, a la escasa sensibilidad con que se redibujó el nuevo borde. El solar resultante ha sustituido su condición original de golfo por una línea recta, anulando la interacción tierra / agua, (característica de los golfos y cabos). Además ha dotado a la parcela de una escala desproporcionada si se compara con cualquier otro espacio urbano existente en Getxo, por lo que el solar permanece siempre vacío, salvo en su extremo más recóndito.

This project will be carried out in the town of Getxo, in the province of Vizcaya, located on the right shore of La Ría and within the area called "La gran Bilbao". Our project begins in a lot very near the sea which was slated for the construction of swimming pools; the original project failed, turning this area into a sort of "no-man's land". This is the main reason which underlies the desire to give part of this land back to the sea. The reasons for which this project initially failed, as well as the positive aspects which make this geographical area a special place can be gathered by analysing the surrounding area: it is a privileged spot due to its location on the border of Getxo with the sea; its proximity to the old port of Getxo, an historical area of great activity, and the calm and secluded area it represents by being not a point of passage, but rather a cul-de-sac. The weak points of the lot are to be found, among other, in the lack of sensitivity with which the new boundaries were drawn. The result is seen in the substitution of the original gulf for a straight line, eradicating the interaction between land and water (characteristic of gulfs and capes). It has also given the plot a disproportionate scale when compared to any other urban space existing in Getxo, for which reason it remains empty, except at its most secluded end.

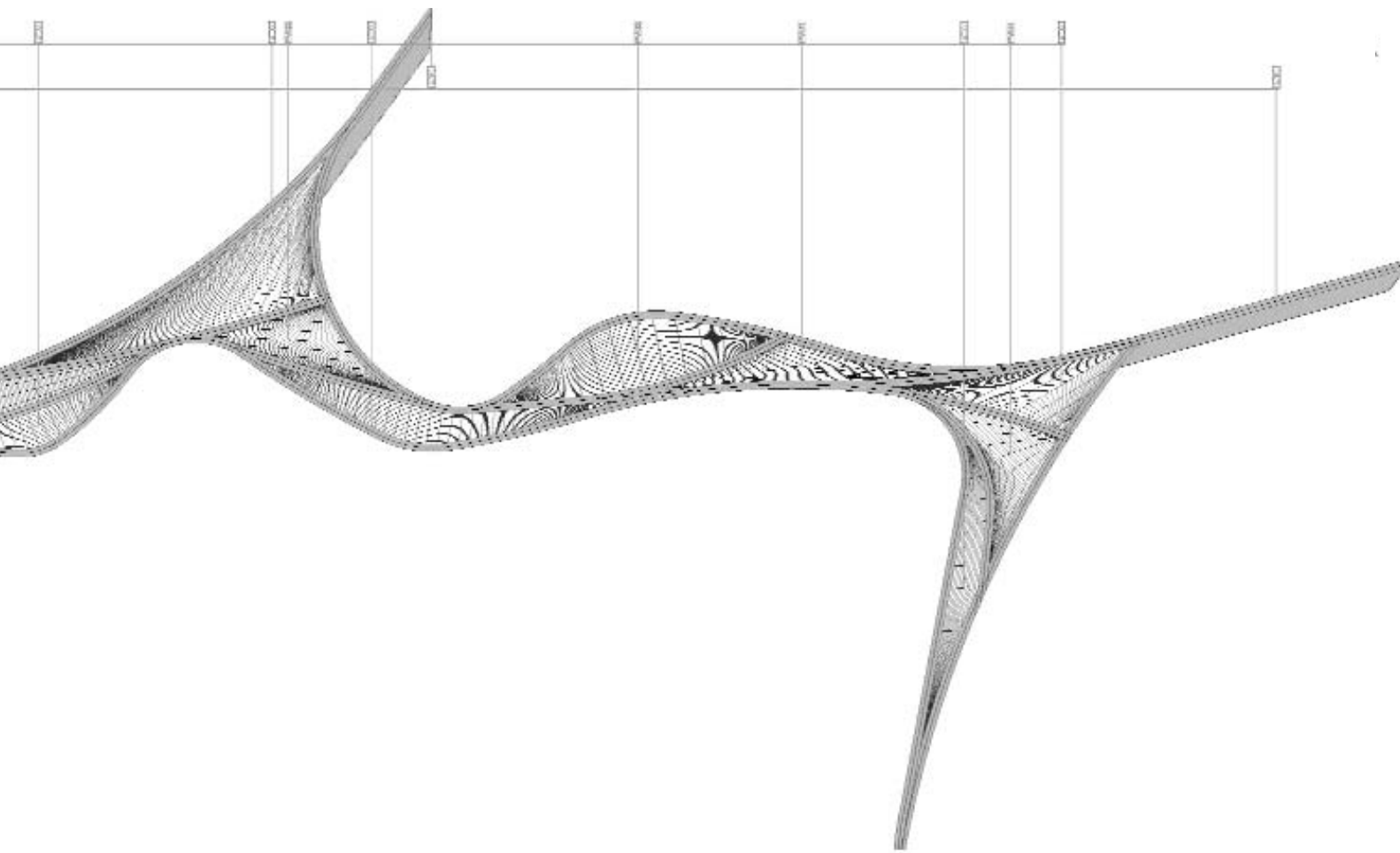

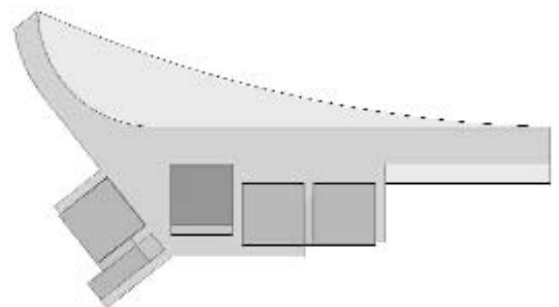
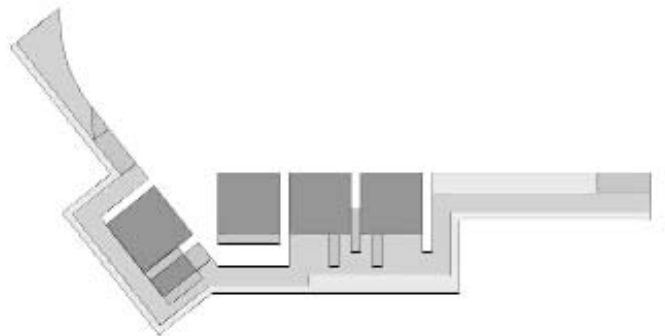
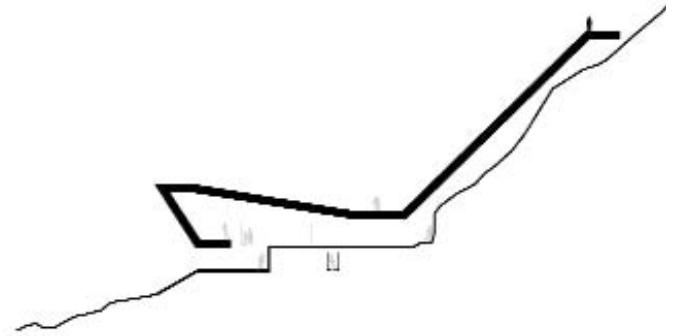

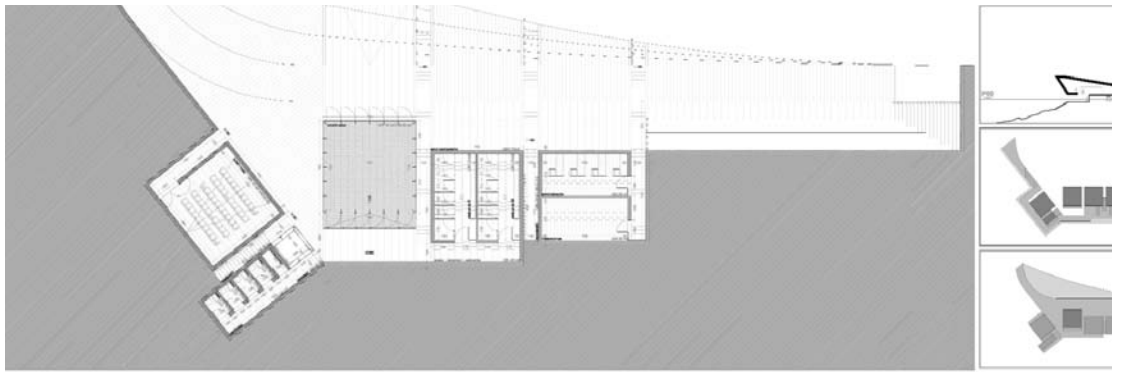

planta baja
ground floor

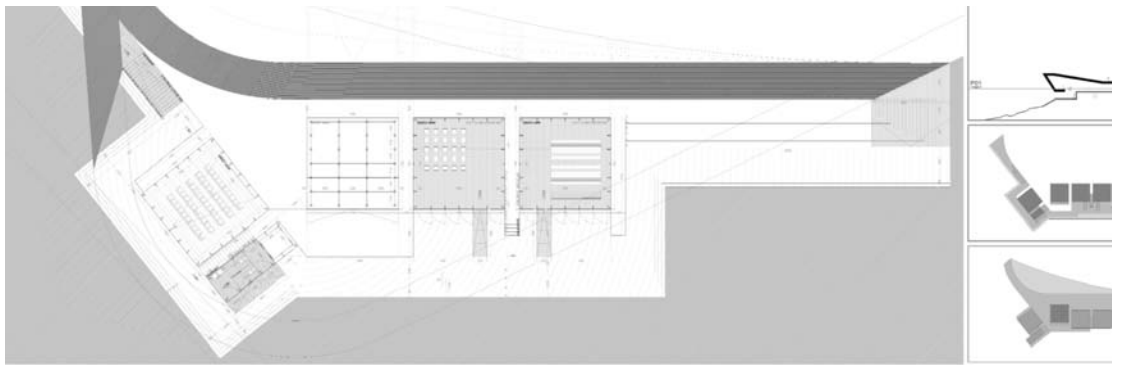

planta primera
first floor

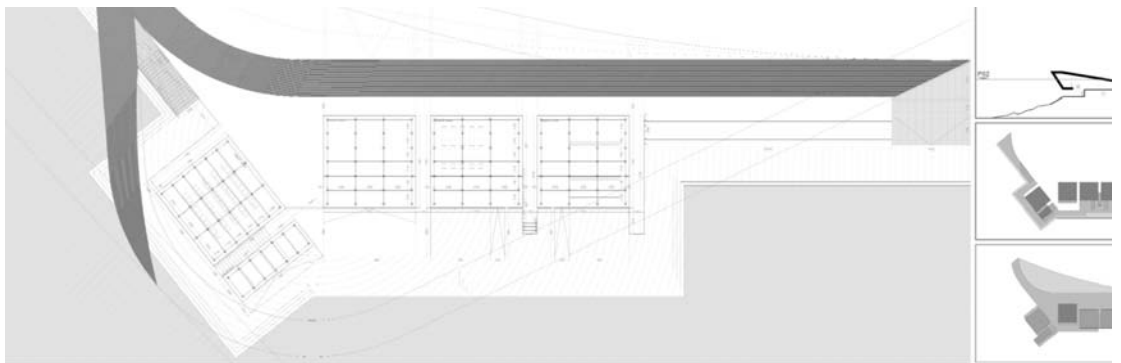

planta segunda
second floor

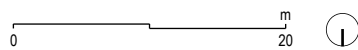

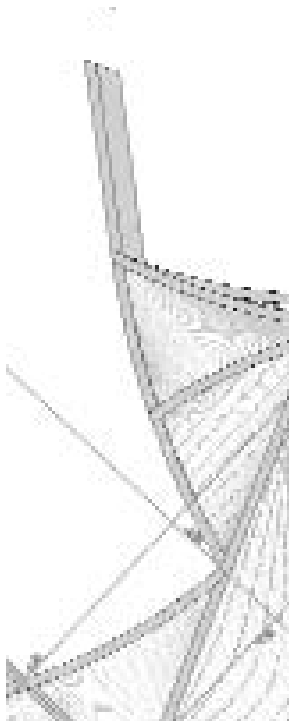

alzado norte
north elevation

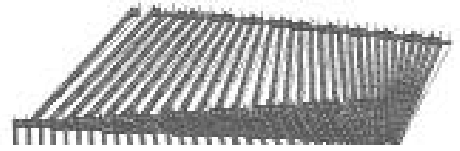

alzado sur
south elevation

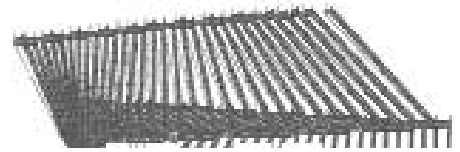

alzado este
west elevation

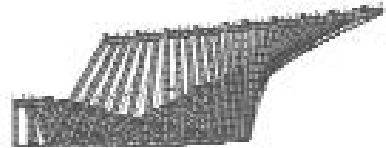

alzado oeste
west elevation

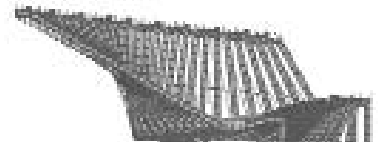

alzado noreste
northeast elevation

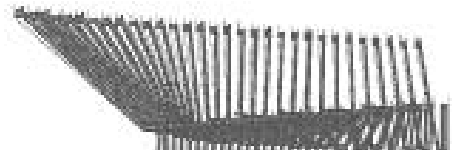

alzado noroeste
northwest elevation



alzado sureste
southeast elevation

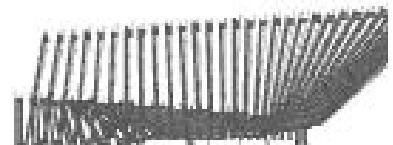

alzado suroeste
southwest elevation





sección 1
section 1

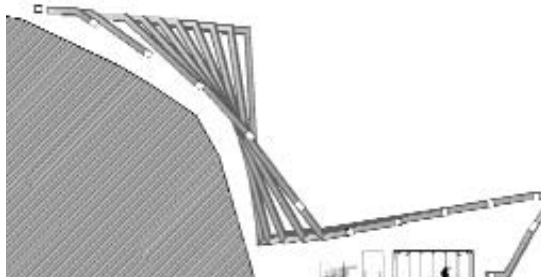

sección 2
section 2

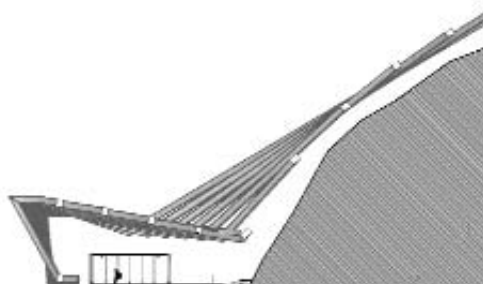

sección 3
section 3

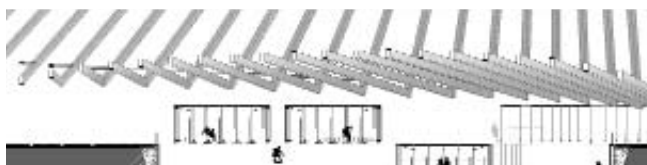

sección 4
section 4

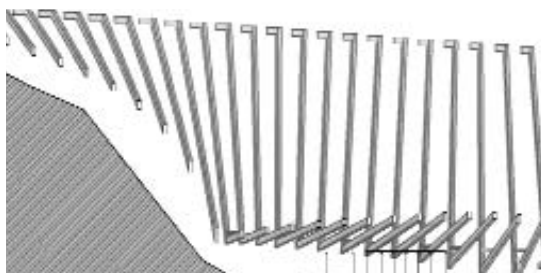

sección 5
section 5

